

Robust. Clever. Eichinger.

Forklift Truck Accessories  
for Industry & Trade

# FORKLIFT ATTACHMENTS



[eichinger-industrie.de](http://eichinger-industrie.de)





Robust. Clever. Eichinger.

# ECOLOGY & VARIETY

The basis of Eichinger Industrie GmbH lies in its roots: the 'foundation stone' was laid back in 1904 with Hans Eichinger's blacksmith's shop. In 1934, Florian Eichinger started the series production of agricultural equipment and wheelbarrows and expanded the range at the end of the 1940s with construction equipment, concrete silos, grabs, tongs and scaffolding trestles.

Florian Eichinger GmbH, which is ISO 9001 certified, has been developing and producing equipment for cranes and forklift trucks for over 70 years.

The foundation of Eichinger Industrie GmbH in 2020 is a response to the needs of the industry and covers the requirements of the sector.

Please contact us, we will be happy to help you find the right solution for you.

## CONTENT

Tipping skips	6
Drop bottom container	14
Silo containers & tipping shovels	18
Forklift buckets & snow clearing equipment	24
Working platforms	30
Lifting gear and load handling attachments	34
Storage systems & transport systems	40
Drum handling	48
Environmental storage technology & Storage systems	56



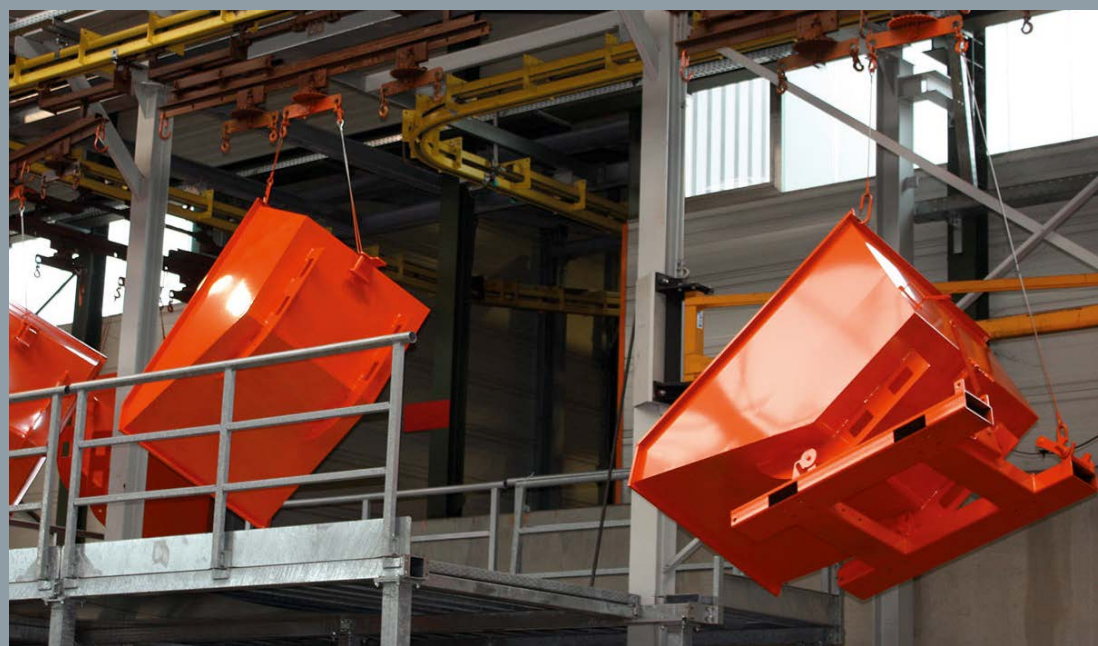

Robust. Clever. Eichinger.

# CONTINUITY & QUALITY

In 2006, the company moved to Mühlhausen, An der Lände 10, to a new-built factory and office building. The site is approx. 80.000 sqm. Here, the team of Florian Eichinger GmbH works every day on constant enhancements of manufacturing, logistics and sales processes and also on continuous growth.

Eichinger Industrie GmbH supplies you with appliances that are manufactured in accordance with the guidelines of the DIN ISO 9001:2015 quality management system. The products are tested for product and occupational safety by the independent testing institute TÜV Nord.





Tipping containers for telescopic handlers 2010 ..... 8



Heavy-duty tipping containers 2011 ..... 8



Side tipping containers 2012 ..... 8



Roll-off skid tipping containers 2013 ..... 9



Bulk tipping containers 2014 ..... 9



Heavy-duty tipping container 2015 ..... 9



Roll-off skip loader 2023 ..... 10



XXXL tipping container 2024 ..... 10



Tipping container sorting system 2025 ..... 10



Waste containers for tipping 2026 ..... 11



Stacking tipper 2028 ..... 11



Tipping gear / traverse 2029 ..... 11



Manual box trolley 2041 ..... 12



Swarf container 2044 ..... 12



Swarf container 2045 ..... 12



Chip tipping container 2046 ..... 13



Forklift tipping skip 2067 ..... 13

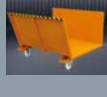

Long timber collection platform 2096..... 13



Robust. Clever. Eichinger.

# COLLECT & TIP OVER

More Information in German language with videos



Tipping skips on [eichinger-industrie.de](http://eichinger-industrie.de)

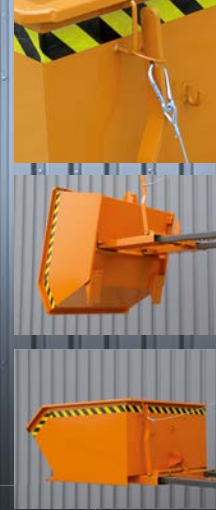

This model is offered in normal scope of delivery without any rollers

## 2010 Tipping Skip for telehandlers/ for telehandlers with auto-lock

Tipping skip made of 3 mm sheet steel, with a sturdy all-round edge. Pick-up without set-up times via drive-in pockets;

Safety device via gas pressure cylinder for automatic locking on the fork. The tipping container is emptied by tilting the fork.

As standard in Pure Orange RAL 2004, Gentian Blue RAL 5010 and Anthracite Grey RAL 7016.

The following options are available at an additional cost:

- Bespoke paint (RAL number required)
- Galvanised version
- Oil- and waterproof welding

Type	I	T	L	B	H	L1	B1	H1	A	G
2010.12	1000	1500	1650	1200	1050	1440	1120	880	450	150

Z = 170 x 70

- I = Volume in litre
- T = Load capacity in kg
- L = Exterior length in mm
- B = Exterior Width in mm
- H = Exterior Height in mm
- L1 = Interior length in mm
- B1 = Interior width in mm
- H1 = Interior height in mm
- A = Prongs distance in mm
- Z = Prongs dimension in mm
- G = Weight in kg

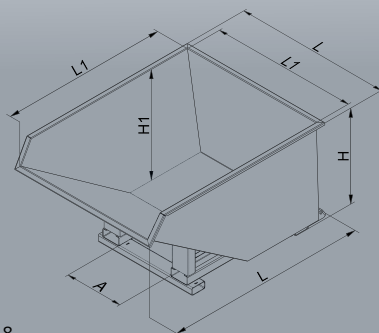

## 2011 Tipping Skip with automatic and protected skid rollers

Designed with a centrally balanced pivot point to allow for optimised load distribution, it has oil and water tight welded joints and all round reinforced edges. The unit can be tipped into any position using a cable pull at the drivers seat, safeguarding against inadvertent slipping. The roller mechanism has an automatic release and there is a sturdy base frame with run in recess.

As standard in Pure Orange RAL 2004, Gentian Blue RAL 5010 and Anthracite Grey RAL 7016.

The following options are available at an additional cost:

- 2 fixed and 2 swivel castors
- Handle
- Solid and multi-part cover
- Lifting coupling
- Bespoke paint (RAL number required)
- Galvanised version
- Stainless steel
- Oil- and waterproof welding

Type	I	T	L	B	H	L1	B1	H1	A	G
2011.4	300	1000	1260	750	910	1040	600	690	250	190
2011.7	400	1000	1260	950	910	1040	800	690	250	200
2011.8	500	1000	1440	790	1080	1250	650	860	250	210
2011.9	600	1000	1440	940	1080	1250	800	860	250	220
2011.10	750	1000	1440	1150	1080	1250	1000	860	600	235
2011.11	800	1500	1440	1190	1080	1250	1050	860	600	260
2011.12	1000	2000	1440	1450	1080	1250	1300	860	800	275
2011.13	1250	2500	1440	1800	1080	1250	1650	860	800	290
2011.14	1500	3000	1440	2150	1080	1250	2000	860	800	350
2011.15	1750	3500	1440	2450	1080	1250	2300	860	800	380
2011.16	2000	3500	1700	1890	1280	1465	1750	1075	800	445
2011.30	2250	3500	1800	1900	1380	1590	1750	1175	800	475
2011.17	2500	4000	1800	2100	1380	1590	1950	1175	800	500
2011.18	3000	4000	1800	2450	1380	1590	2300	1175	800	550

Z = 200 x 80

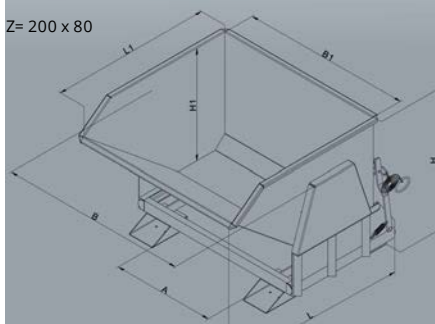

## 2012 Tipping Skip low sided, with automatic rollers

This low sided tipping skip has a 3mm sheet-steel edged profile with oil and water tight welded joints. The low profile allows for optimum tipping angles and can be moved into any position using a cable pull at the drivers seat, safeguarding against inadvertent slipping. The roller mechanism has an automatic release and there is a sturdy base with run in recess. As standard in Pure Orange RAL 2004, Gentian Blue RAL 5010 and Anthracite Grey RAL 7016. The following options are available at an additional cost:

- 2 fixed and 2 swivel castors
- Handle
- Solid and multi-part cover
- Hydraulic tipping attachment
- Tipping brake
- Side wall
- Lifting lugs
- Lifting coupling
- Bespoke paint (RAL number required)
- Galvanised version
- Stainless steel
- Oil- and waterproof welding

Type	I	T	L	B	H	L1	B1	H1	A	G
2012.4	300	1500	1410	700	580	1135	620	500	105	110
2012.7	400	1500	1410	750	630	1160	670	550	130	120
2012.8	500	1500	1410	800	680	1190	720	600	180	130
2012.10	750	1500	1410	1280	680	1190	1200	600	480	160
2012.12	1000	2000	1550	1300	750	1325	1220	640	480	180
2012.14	1500	2000	1640	1300	1050	1420	1220	980	480	210

Z = 200 x 60

- I = Volume in litre
- T = Load capacity in kg
- L = Exterior length in mm
- B = Exterior Width in mm
- H = Exterior Height in mm
- L1 = Interior length in mm
- B1 = Interior width in mm
- H1 = Interior height in mm
- A = Prongs distance in mm
- Z = Prongs dimension in mm
- G = Weight in kg

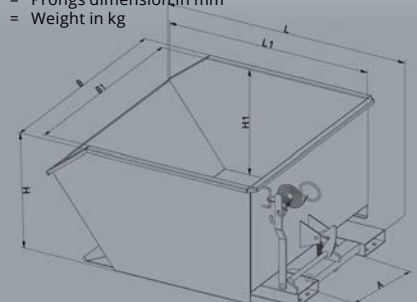





### 2013 Tipping Skip high sided

Rectangular shape with a 3mm sheet-steel edged profile with oil and water tight welded joints, this tipping skip comes with a 4 way fork pocket entry to allow the unit to be placed exactly where needed. Each unit has all round edge reinforcement, mechanical tipping via rope pull, slip protection and is also supplied with a fixed heel pin and 'tear-drop' safety catch to ensure the skip doesn't discharge during transit. As standard in Pure Orange RAL 2004, Gentian Blue RAL 5010 and Anthracite Grey RAL 7016. The following options are available at an additional cost:

- 2 fixed and 2 swivel castors
- Handle
- Solid and multi-part cover
- Lifting lugs
- Lifting coupling
- Bespoke paint (RAL number required)
- Galvanised version
- Stainless steel
- Oil- and waterproof welding

Type	I	T	L	B	H	L1	B1	H1	A	G
2013.4	300	1500	1350	880	920	1060	800	640	420	190
2013.8	500	1500	1370	980	1060	1235	900	780	580	210
2013.9	600	1500	1370	1080	1060	1235	1000	780	580	220
2013.10	750	1500	1370	1180	1060	1235	1100	780	580	230
2013.12	1000	1500	1370	1580	1060	1235	1500	780	580	245
2013.13	1250	2000	1670	1340	1300	1545	1250	1020	580	315
2013.14	1500	2000	1670	1590	1300	1545	1500	1020	580	340

Z= 190 x 85

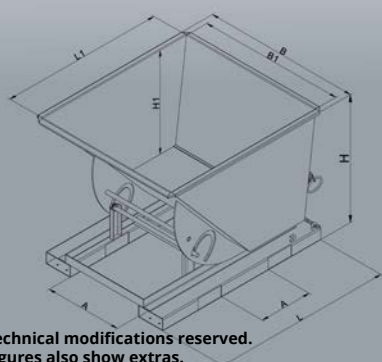

Technical modifications reserved. Figures also show extras.

### 2014 Tipping Skip low sided, with acute tipping angle

This low sided tipping skip is designed with an acute tipping angle to allow for operation in tight spaces. The base and container are fixed with a scissor type mechanism to ensure maximum manoeuvrability. The base frame comes with integrated docking pockets for protection against accidental slipping and discharge.

As standard in Pure Orange RAL 2004, Gentian Blue RAL 5010 and Anthracite Grey RAL 7016.

The following options are available at an additional cost:

- 2 fixed and 2 swivel castors
- Handle
- Solid and multi-part cover
- Lifting coupling
- Bespoke paint (RAL number required)
- Galvanised version
- Stainless steel

Type	I	T	L	B	H	L1	B1	H1	A	G
2014.4	300	1500	1450	680	725	1340	600	625	185	125
2014.7	400	1500	1450	830	725	1340	750	625	335	140
2014.8	500	1500	1530	830	795	1420	750	695	335	150
2014.10	750	1500	1710	1080	905	1600	1000	805	595	200
2014.12	1000	1500	1710	1380	905	1600	1300	805	890	220

Z= 190 x 80

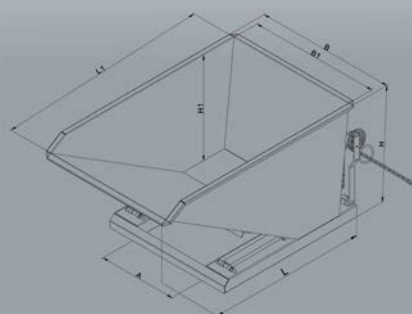

### 2015 Tipping Skip high sided, with obtuse tipping angle

This high sided tipping skip has an operating angle of 90 degrees, with a catching mechanism to prevent over tipping. This lock can be operated from the driver seat - when the unit is returned to the upright position it will automatically lock back into place.

As standard in Pure Orange RAL 2004, Gentian Blue RAL 5010 and Anthracite Grey RAL 7016.

The following options are available at an additional cost:

- 2 fixed and 2 swivel castors
- Handle
- Solid and multi-part cover
- Lifting coupling
- Bespoke paint (RAL number required)
- Galvanised version
- Stainless steel

Type	I	T	L	B	H	L1	B1	H1	A	G
2015.4	300	1000	1700	780	980	1340	700	580	180	140
2015.7	400	1000	1700	780	1055	1450	700	630	180	150
2015.8	500	1000	1750	780	1125	1610	700	710	180	170
2015.9	600	1000	1750	780	1200	1610	700	780	180	190
2015.10	750	1000	1900	960	1370	1810	880	920	360	220
2015.11	800	1500	1900	830	1300	1790	750	870	230	230
2015.12	1000	1500	1900	1080	1370	1810	1000	920	480	250
2015.13	1250	1500	1950	1080	1500	1830	1000	1050	480	290
2015.14	1500	1500	1900	1480	1400	1740	1400	950	550	375
2015.15	1750	2000	1900	1580	1400	1740	1500	950	650	390
2015.16	2000	2000	1950	1580	1500	1780	1500	1050	650	405
2015.21	2250	2500	1950	1780	1500	1780	1700	1050	750	420
2015.17	2500	2500	2000	1780	1550	1810	1700	1100	750	440

Z= 200 x 80

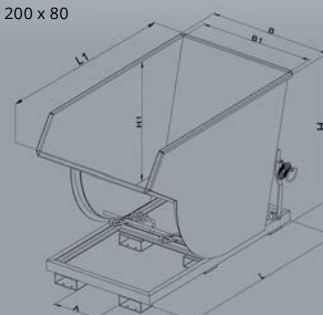



## 2023 Square Tipping Skip

Manufactured from high-grade sheet steel with all round edge reinforcement and oil and water tight joints, this tipping skip provides mechanical tipping from the driver seat via a rope pull. The safety chain prevents unintentional slippage.

As standard in Pure Orange RAL 2004, Gentian Blue RAL 5010 and Anthracite Grey RAL 7016.

The following options are available at an additional cost:

- 2 fixed and 2 swivel castors
- Handle
- Solid and multi-part cover
- Lifting lugs
- Lifting coupling
- Bespoke paint (RAL number required)
- Galvanised version
- Stainless steel
- Oil- and waterproof welding

Type	I	T	L	B	H	L1	B1	H1	A	G
2023.1	150	750	1000	715	540	855	600	425	255	78
2023.4	300	750	1330	650	830	1200	580	710	190	115
2023.8	500	1000	1330	980	830	1200	910	710	190	130
2023.10	750	1000	1330	1440	830	1200	1370	710	590	160
2023.12	1000	1500	1330	1900	830	1200	1825	710	590	185
2032.13	1250	1500	1830	1130	1200	1760	1050	1080	590	225
2023.14	1500	1500	1830	1330	1200	1760	1250	1080	590	235
2023.15	1750	1500	1830	1530	1200	1760	1450	1080	590	255
2023.16	2000	2000	1830	1730	1200	1760	1650	1080	590	280
2023.17	2500	2000	1830	2150	1200	1760	2070	1080	590	312

Z= 200 x 80

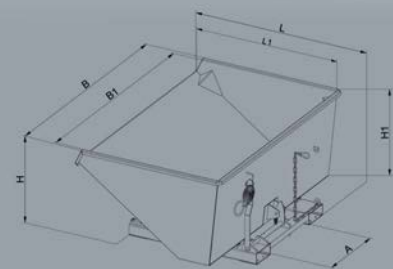

## 2024 Tipping Skip extra large capacity

For extra large loads, this tipping skip has section side walls and robust triangular supports which allows for controlled operation of the unit. They are manufactured using high-grade sheet steel, have a reinforced base frame with integrated docking pockets and come with all round pan sections with double reinforcement at the tipping edge. There is extra support built into the swivel joint and can be tipped up to a 90 degree angle using the rope pull. Available in 3000L, 4000L and 5000L capacity. As standard in Pure Orange RAL 2004, Gentian Blue RAL 5010 and Anthracite Grey RAL 7016.

The following options are available at an additional cost:

- 2 fixed and 2 swivel castors
- Handle
- Solid and multi-part cover
- Hydraulic tipping attachment
- Tipping brake
- Lifting coupling
- Bespoke paint (RAL number required)
- Galvanised version
- Stainless steel
- Oil- and waterproof welding

Type	I	T	L	B	H	L1	B1	H1	Z	G
2024.18	3000	2500	2440	2260	1230	1930	2000	930	200x80	525
2024.20	4000	2500	2440	2260	1495	1930	2000	1195	200x80	578
2024.22	5000	2500	2440	2260	1750	1930	2000	1460	200x80	612

A= 590

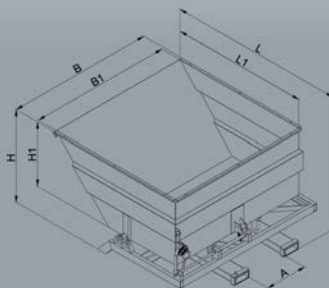

## 2025 Tipping Skip sorting system "2in1" or "3in1"

The ideal solution for separating recyclable materials and waste on site. 2 or 3 containers in waste specific colours, operated as one complete unit but tipped out individually into the relevant collecting container. Comes with rope pull for mechanical tipping and to prevent slippage.

Painted in RAL2004 orange Eichinger as standard \*RAL colours to be chosen at point of order.

The following options are available at an additional cost:

- 2 fixed and 2 swivel castors
- Handle
- Solid and multi-part cover
- Lifting lugs
- Lifting coupling
- Bespoke paint (RAL number required)\*
- Galvanised version
- Stainless steel
- Oil- and waterproof welding

Type	I	T	L	B	H	L1	B1	H1	A	Z	G
2025. Duo	2x 900l	1500	1680	1640	980	1625	750	870	600	200x80	250
2025. Trio	3x 600l	1500	1680	1700	980	1625	500	870	600	200x80	300

Legend for abbreviations in the tables

- I = Volume in litre
- T = Load capacity in kg
- L = Exterior length in mm
- B = Exterior Width in mm
- H = Exterior Height in mm
- L1 = Interior length in mm
- B1 = Interior width in mm
- H1 = Interior height in mm
- A = Prongs distance in mm
- Z = Prongs dimension in mm
- G = Weight in kg

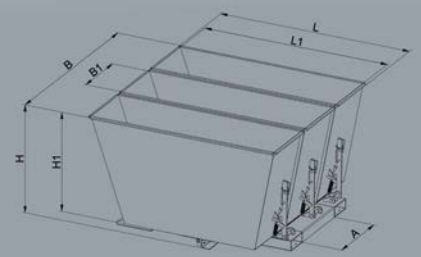



**2026 Tipping Skip**  
with round cover

Designed for easy loading and unloading with conical side walls, this tipping skip has a reinforced base frame and solid all round edge section. The tipping mechanism can be unlocked via rope pull and comes with a chain to prevent slippage.

As standard in Pure Orange RAL 2004, Gentian Blue RAL 5010 and Anthracite Grey RAL 7016, with galvanised cover.

The following options are available at an additional cost:

- 2 fixed and 2 swivel castors
- Handle
- Lifting coupling
- Bespoke paint (RAL number required)
- Galvanised version
- Stainless steel
- Oil- and waterproof welding

Type	I	T	L	B	H	Z	G
2026.10	750	1000	1800	750	1230	200x80	205
2026.12	1000	1000	1800	950	1230	200x80	225

**2028 Stacking Tipper**

Designed to allow for stacking of up to 3 units fully loaded. The side walls, edge corners, and edge roundings have been reinforced to allow for heavy loads and ensure extra support of the load capacity during loading and unloading. Manufactured from high grade sheet steel with oil and water tight joints.

To be used in conjunction with our 2029 Tipping Gear.

As standard in Pure Orange RAL 2004, Gentian Blue RAL 5010 and Anthracite Grey RAL 7016.

The following options are available at an additional cost:

- removable intermediate bottom
- 2 fixed and 2 swivel castors
- Handle
- Solid and multi-part cover
- oil and watertight
- Lifting lugs
- Lifting coupling
- Bespoke paint (RAL number required)
- Galvanised version
- Stainless steel

Type	I	T	L	B	H	L1	B1	H1	G
2028.4	300	500	980	1070	620	890	845	515	55
2028.8	550	1000	1080	1070	900	990	845	795	75
2028.10	700	1500	1280	1070	900	1190	845	795	85
2028.12	900	2000	1280	1260	900	1190	1035	795	92
2028.14	1500	2000	1365	1580	1150	1275	1350	1045	155
2028.16	2000	2000	1365	1980	1150	1275	1750	1045	180

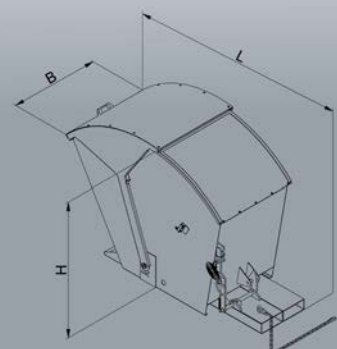

Technical modifications reserved. Figures also show extras.

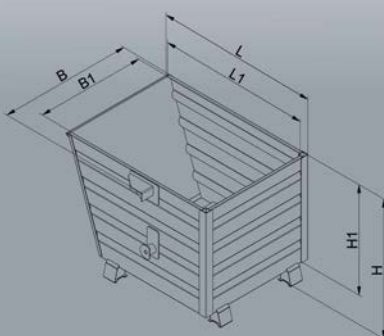

**2029 Tipping Gear**  
for use with fork lift and crane

A twist-free lifting beam for transportation and tipping of stackable containers such as the 2028 Stacking Tipper. It is equipped with fork lift docking rails and steel lifting lugs for crane operation. The tipping mechanism can be operated via rope pull.

As standard in Pure Orange RAL 2004, Gentian Blue RAL 5010 and Anthracite Grey RAL 7016.

The following options are available at an additional cost:

- Bespoke paint (RAL number required)
- Galvanised version
- Stainless steel

Type	suitable for	T	L	B	H	A	Z
2029.4	2028.4	1000	1350	1030	1030	230	200x80
2029.8	2028.8	1500	1350	1030	1030	230	200x80
2029.10	2028.10	1800	1350	1030	1030	230	200x80
2029.12	2028.12	2000	1350	1220	1030	350	200x80
2029.14	2028.14	2200	1450	1540	1310	550	200x80
2029.16	2028.16	2500	1450	1930	1310	550	200x80

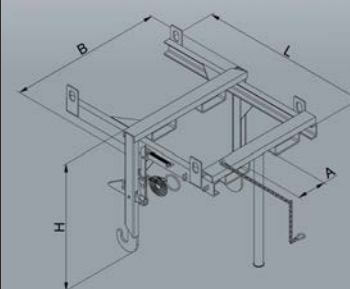



## 2041 Manual Box Trolley

Designed to be used manually or with a forklift, the box trolley is extremely manoeuvrable to allow for use in tight spaces. It comes with 2 fixed and 2 swivel castors. Manufactured from high grade sheet steel, all round edge reinforcement and anti-slip protection.

As standard in Pure Orange RAL 2004, Gentian Blue RAL 5010 and Anthracite Grey RAL 7016.

The following options are available at an additional cost:

- Solid and multi-part cover
- Chip version
- Bespoke paint (RAL number required)
- Galvanised version

Type	I	T	L	B	H	L1	B1	H1	A	Z	G
2041.2	200	300	1050	750	1030	920	520	590	330	200x80	105
2041.3	250	300	1050	830	1030	920	630	590	410	200x80	110
2041.6	375	300	1330	900	1150	1200	620	710	480	200x80	130
2041.8	500	300	1330	1050	1150	1200	770	710	630	200x80	135
2041.9	600	300	1330	1180	1150	1200	900	710	760	200x80	140
2041.10	750	300	1470	1100	1390	1330	820	920	680	200x80	210
2041.11	800	300	1470	1160	1390	1330	875	920	740	200x80	215
2041.12	1000	300	1470	1340	1390	1330	1060	920	920	200x80	230

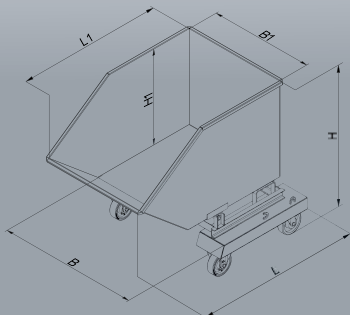

## 2044 Swarf Container with perforated sheet and drain valve

This oil and water tight container is fitted with a perforated sheet separator (sheet 3mm, raster 6mm) at 100mm above the container bottom for separating swarf material and liquid. Boring water and oil can both be captured in the collecting container and separated via the drain valve. The tipping mechanism works via a rope pull and the unit has anti-slip protection.

As standard in Pure Orange RAL 2004, Gentian Blue RAL 5010 and Anthracite Grey RAL 7016.

The following options are available at an additional cost:

- 2 fixed and 2 swivel castors
- Handle
- Solid and multi-part cover
- Lifting lugs
- Lifting coupling
- Bespoke paint (RAL number required)
- Galvanised version
- Stainless steel

Type	I	T	L	B	H	L1	B1	H1	A	Z	G
2044.4	300	1000	1410	700	580	1135	620	400	105	200x60	130
2044.8	500	1000	1410	800	680	1190	720	500	180	200x60	150
2044.10	750	1000	1410	1280	680	1190	1200	500	480	200x60	190
2044.12	1000	1500	1550	1300	750	1325	1220	540	480	200x60	210
2044.14	1500	1500	1640	1300	1050	1420	1220	880	480	200x60	255

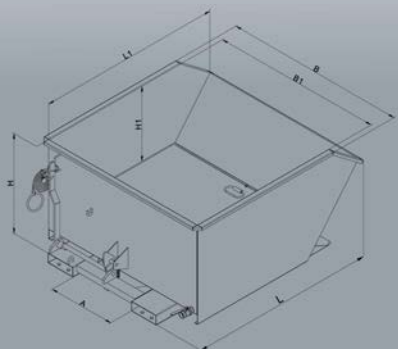

## 2045 Swarf Container with perforated sheet

This large volume tipping skip complete with roller mechanism is fitted with a galvanised perforated sheet (sheet 3mm, raster 6mm) and drain valve for separation and collection of liquids contained within the swarf material. The unit has oil and water tight joints and reinforced edges on a strengthened base frame with 2 fixed and 2 swivel castors. For use with a forklift, the tipping mechanism is operated via a rope pull from the drivers seat.

As standard in Pure Orange RAL 2004, Gentian Blue RAL 5010 and Anthracite Grey RAL 7016.

The following options are available at an additional cost:

- Solid and multi-part cover
- Lifting lugs
- Lifting coupling
- Bespoke paint (RAL number required)
- Galvanised version
- Stainless steel

Type	I	T	L	B	H	L1	B1	H1	A	Z	G
2045.4	300	1000	1700	780	1175	1340	700	580	180	200x80	140
2045.7	400	1000	1700	780	1250	1450	700	630	180	200x80	150
2045.8	500	1000	1750	780	1320	1610	700	710	180	200x80	170
2045.9	600	1000	1750	780	1395	1610	700	780	180	200x80	190
2045.10	750	1000	1900	960	1565	1810	880	920	360	200x80	220
2045.11	800	2500	1900	830	1540	1790	750	870	230	200x80	230
2045.12	1000	2500	1900	1080	1610	1810	1000	920	480	200x80	250
2045.13	1250	2500	1950	1080	1740	1830	1000	1050	480	200x80	290
2045.14	1500	2500	1900	1480	1640	1740	1400	950	550	200x80	375
2045.15	1750	2500	1900	1580	1640	1740	1500	950	650	200x80	390
2045.16	2000	2500	1950	1580	1740	1780	1500	1050	650	200x80	405
2045.21	2250	2500	1950	1780	1740	1780	1700	1050	750	200x80	420
2045.17	2500	2500	2000	1780	1790	1810	1700	1100	750	200x80	440

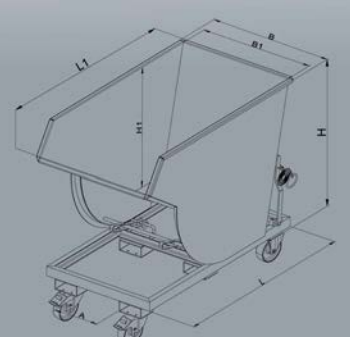



## 2046

### Chip container

low sided, with sieve and drain valve

Low sided, rectangular skip with oil and water tight joints and a strainer insert and drain valve. The unit can be tilted in any position using the cable pull from the drivers seat. Complete with fork lift pockets for ease of use.

As standard in Pure Orange RAL 2004, Gentian Blue RAL 5010 and Anthracite Grey RAL 7016.

The following options are available at an additional cost:

- 2 swivel castors and 2 fixed castors
- Handle
- Solid and multi-part cover
- Hydraulic tipping attachment
- Tipping brake
- Side wall attachment
- Trailer coupling
- Bespoke paint (RAL number required)
- Galvanised version
- Stainless steel

Type	I	T	L	B	H	L1	B1	H1	A	Z	G
2046.1	150	1000	1410	700	450	1160	620	380	105	200x60	85
2046.2	250	1000	1410	750	450	1160	670	380	130	200x60	95
2046.4	300	1000	1410	700	580	1160	620	500	105	200x60	110
2046.7	400	1000	1410	750	630	1160	670	550	130	200x60	120
2046.8	500	1000	1410	800	680	1190	720	600	180	200x60	130
2046.10	750	1000	1410	1280	680	1190	1200	600	480	200x60	160
2046.12	1000	1500	1550	1300	750	1325	1220	640	480	200x60	180
2046.14	1500	1500	1640	1300	1050	1420	1220	980	480	200x60	210

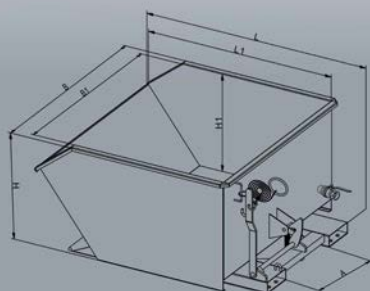

Technical modifications reserved.  
Figures also show extras.

## 2067

### Tipping Skip

Tips 2 sides with 4 sided docking

Versatile tipping skip with 2 way tipping and secure docking on 4 sides. Space saving, ideal for smaller and busy sites with an optimised load capacity of 500kg. Manufactured using high grade sheet steel with reinforced edges and slip protection.

As standard in Pure Orange RAL 2004, Gentian Blue RAL 5010 and Anthracite Grey RAL 7016.

The following options are available at an additional cost:

- 2 fixed and 2 swivel castors
- Bespoke paint (RAL number required)
- Galvanised version

Type	I	T	L	B	H	L1	B1	H1	A/A1	Z	G
2067.4	300	500	845	920	995	600	870	730	250/150	200x80	85
2067.9	600	750	1445	920	995	1200	870	730	250/650	200x80	130

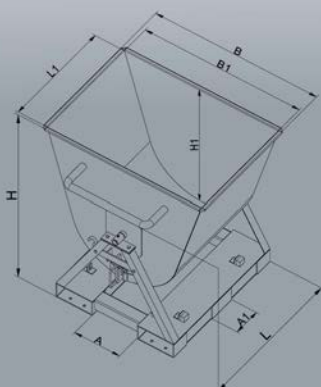

## 2096

### Long Timber Collection Platform

with side ramps

Open ended, large capacity flat bottomed collection container with 2 side ramps. The edges and intermediate braces are reinforced with steel tube sections for extra strength. For forklift use, the forward tipping action can be operated from the drivers seat via the rope pull.

As standard in Pure Orange RAL 2004, Gentian Blue RAL 5010 and Anthracite Grey RAL 7016.

The following options are available at an additional cost:

- 2 fixed and 2 swivel castors
- Bespoke paint (RAL number required)
- Galvanised version

Type	T	L	B	H	G
2096	500	1680	1500	840	185

Legend for abbreviations in the tables

- I = Volume in litre
- T = Load capacity in kg
- L = Exterior length in mm
- B = Exterior Width in mm
- H = Exterior Height in mm
- L1 = Interior length in mm
- B1 = Interior width in mm
- H1 = Interior height in mm

- A = Prongs distance in mm
- Z = Prongs dimension in mm
- G = Weight in kg

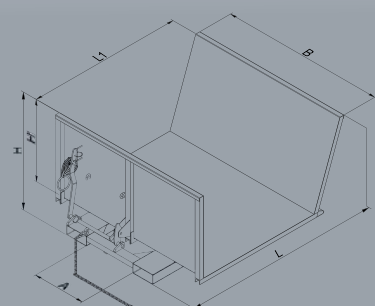



Drop bottom skip 2032 ..... 16



Drop bottom skip 2033 ..... 16



Rubble skip 2034 ..... 16



Building material skip with hinged floor 2035 ..... 16



Hinged-bottom waste skip 2036 ..... 17



Lattice box 2037 ..... 17



Drop bottom skip 2039 ..... 17



Robust. Clever. Eichinger.

# COLLECT & EMPTY

More Information in German language with videos



Drop bottom skips on [eichinger-industrie.de](http://eichinger-industrie.de)



## 2032 Drop Bottom Skip square

The square design and reinforced 3 mm steel walls allow for easy stacking of the 2032. The robust, spring secured base can be operated via rope pull from the drivers seat. The spring base mechanism automatically locks closed once the unit has been returned to a flat surface. The welded support brackets allow for use with either a forklift or crane and the chain provides protection from slippage.

As standard in Pure Orange RAL 2004, Gential Blue RAL 5010 and Anthracite Grey RAL 7016.

The following options are available at an additional cost:

- 2 fixed and 2 swivel castors
- Solid and multi-part cover
- Bespoke paint (RAL number required)
- Galvanised version
- Stainless steel

Type	I	T	L	B	H	L1	B1	H1	A	Z	G
2032.4	300	1000	1330	1000	550	1200	900	400	600	175x70	160
2032.8	500	1000	1330	1000	650	1200	900	500	600	175x70	170
2032.10	750	1500	1330	1000	850	1200	900	700	600	175x70	190
2032.12	1000	2000	1330	1000	1070	1200	900	920	600	175x70	245
2032.14	1500	2000	1930	1000	1070	1800	900	920	600	175x70	270
2032.16	2000	2000	1930	1000	1370	1800	900	1220	600	175x70	370

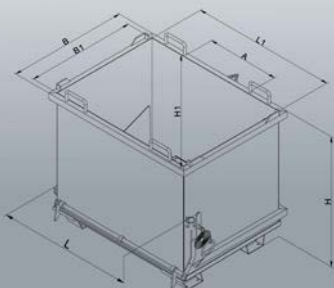

## 2034 Rubble Skip with reinforced drop bottom

Technical data are identical to type 2032, see table

## 2033 Drop Bottom Skip conical

The conical design allows for easy stacking of units. The locked, hinged base can be opened via the rope pull and springs from the drivers seat. The skip opens at a 90 degree angle and locks automatically when returned to a flat surface. The welded support brackets allow use of the unit with either forklift or crane.

As standard in Pure Orange RAL 2004, Gential Blue RAL 5010 and Anthracite Grey RAL 7016.

The following options are available at an additional cost:

- 2 fixed and 2 swivel castors
- Solid and multi-part cover
- Bespoke paint (RAL number required)
- Galvanised version
- Stainless steel

Type	I	T	L	B	H	L1	B1	H1	A	Z	G
2033.8	500	1000	1250	1060	890	1130	935	665	570	200x80	170
2033.10	750	1500	1250	1060	990	1130	935	765	570	200x80	190
2033.12	1000	2000	1250	1060	1240	1130	935	1015	570	200x80	210

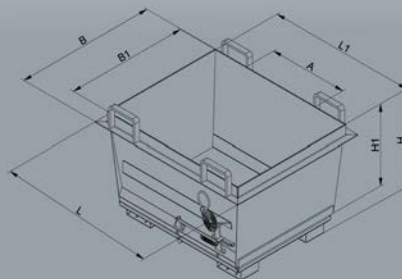

## 2035 Building Material Skip with hinged bottom

Versatile materials management via top or bottom lifting from both crane and forklift. Rectangular and stackable, with smooth interior walls this is ideal for bulk loading. The unit has a reinforced, drop base with feet and can be operated via rope pull from the driver seat.

As standard in Pure Orange RAL 2004, Gential Blue RAL 5010 and Anthracite Grey RAL 7016.

The following options are available at an additional cost:

- 2 swivel castors and 2 fixed castors
- Lid, multi-part
- Bespoke paint (RAL number required)
- Galvanised version
- Stainless steel version
- Stone tong release

Type	I	T	L	B	H	L1	B1	H1	A	Z	G
2035.4	300	1000	1330	1000	550	1200	900	400	600	175x70	170
2035.8	500	1000	1330	1000	650	1200	900	500	600	175x70	185
2035.10	750	1500	1330	1000	850	1200	900	700	600	175x70	215
2035.12	1000	2000	1330	1000	1070	1200	900	920	600	175x70	250

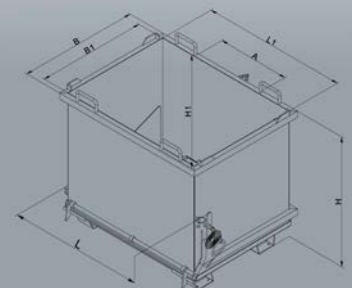





**2036 Drop Bottom Skip**  
with partition walls and separate opening hinged bottoms

The multi-part container with separately operable hinged bottoms is ideal not only for separating waste but also helpful in working areas with different small pieces which can be poured. With massive, reinforced hinged bottoms with legs, guaranteeing an under-riding height of 100 mm. Available with inner walls for 2 or 3 separate inner divisions. With all-round edge reinforcement and slip protection. For use with crane and fork lift.

As standard in Pure Orange RAL 2004, Gentian Blue RAL 5010 and Anthracite Grey RAL 7016.

The following options are available at an additional cost:

- 2 fixed and 2 swivel castors
- Solid and multi-part cover
- Bespoke paint (RAL number required)
- Galvanised version
- Stainless steel
- transport trolley

Type	I	T	L	B	H	L1	B1	H1	A	Z	G
2036.12	x 900	1500	1890	1060	1190	1795	915	1050	670	175x70	252
2036.23	x 600	1500	1890	1060	1190	1795	915	1050	670	175x70	280

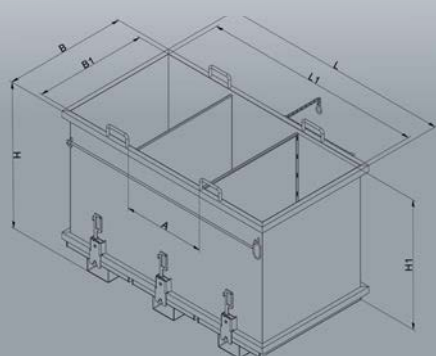

Technical modifications reserved. Figures also show extras.

**2037 Lattice Box**  
with lockable hinged base

Hinged bottom container with wire mesh side walls (mesh spacing 50mm x 50mm x 5mm). The hinged base is constructed from high grade sheet steel with resting feet. It is unlocked via a cable pull operated from the drivers seat. This stackable unit can be used with forklift or crane and has welded corners for position fixing whilst stacked. A chain prevent unintentional slippage.

As standard in Pure Orange RAL 2004, Gentian Blue RAL 5010 and Anthracite Grey RAL 7016.

The following options are available at an additional cost:

- 2 fixed and 2 swivel castors
- Stainless steel
- Bespoke paint (RAL number required)
- Galvanised version

Type	I	T	L	B	H	L1	B1	A	Z	G
2037.12	1000	500	1335	1080	1160	1200	900	595	160 x 70	200

Legend for abbreviations in the tables

- I = Volume in litre
- T = Load capacity in kg
- L = Exterior length in mm
- B = Exterior Width in mm
- H = Exterior Height in mm
- L1 = Interior length in mm
- B1 = Interior width in mm
- H1 = Interior height in mm
- A = Prongs distance in mm
- Z = Prongs dimension in mm
- G = Weight in kg

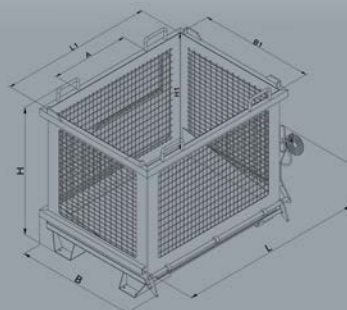

**2039 Drop Bottom Skip**

Box-shaped hinged floor container for forklift trucks with smooth inner walls. The solid container can be stacked 3 high and can be picked up by forklift and crane. The bottom flap is unlocked by pulling a cable from the driver's seat. The bottom flap closes automatically when it is placed on the floor. Thanks to the 100 mm ground clearance, the hinged floor container can also be moved with a pallet truck. With chain lock. With 4 crane eyes and stacking corners.

Translated with DeepL.com (free version)

As standard in Pure Orange RAL 2004, Gentian Blue RAL 5010 and Anthracite Grey RAL 7016.

The following options are available at an additional cost:

- 2 fixed and 2 swivel castors
- Solid and multi-part cover
- Bespoke paint (RAL number required)
- Centre panels for base flap

Type	I	T	L	B	H	A	Z	G
2039.8	500	1000	850	1250	850	420	175x70	130
2039.10	750	1000	850	1250	1150	420	175x70	150
2039.12	1000	1000	1045	1250	1150	420	175x70	165
2039.14	1500	1500	1045	1850	1150	620	175x70	210
2039.16	2000	1500	1045	1850	1450	620	175x70	240

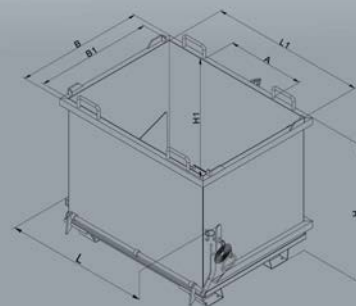



Silo container 2051 .....20



Silo container 2052 .....20



Silo container 2058 .....21



Silo container 2053 .....21



Silo container 2054 .....21

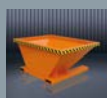

Filling hopper 2056 .....22



Transfer silo 2057 .....22



Loading shovel 2061 .....22

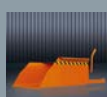

Tipping shovel 2062 .....23

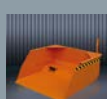

Tipping shovel 2063 .....23



Loading shovel 2064 .....23



Robust. Clever. Eichinger.

# SHOVELLING & FILLING

More Information in German language with videos



Tipping shovels on [eichinger-industrie.de](http://eichinger-industrie.de)



Silo containers on [eichinger-industrie.de](http://eichinger-industrie.de)



RAL 2004



RAL 5010

Almost all appliances from Eichinger Industrie are available in these RAL colors or in the special color of your choice



RAL 7016



Galvanised



Also available as model 2062 with closed forklift pockets



### 2051 Silo Container on rollers with central, lever operated outlet

This unit is square in design with a conical base that has a central clam shell gate mechanism operated using the manual handle. The unit comes with 2 fixed and 2 swivel castors complete with locking brake. Manufactured from high grade sheet steel the unit has reinforced edge sections.

As standard in Pure Orange RAL 2004, Gentian Blue RAL 5010 and Anthracite Grey RAL 7016.

The following options are available at an additional cost:

- Lifting lugs
- Bespoke paint (RAL number required)
- Galvanised version
- Stainless steel

Type	I	T	L	B	H	L1	B1	TA	G
2051.4	300	750	1175	775	1200	960	710	300x300	120
2051.9	600	1000	1175	775	1580	960	710	300x300	145

Legend for abbreviations in the tables

- I = Volume in litre
- T = Load capacity in kg
- L = Exterior length in mm
- B = Exterior Width in mm
- H = Exterior Height in mm
- L1 = Interior length in mm
- B1 = Interior width in mm
- H1 = Interior height in mm
- TA = Hopper outlet in mm
- A = Prongs distance in mm
- Z = Prongs dimension in mm
- G = Weight in kg

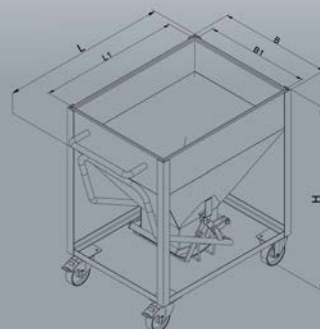

### 2052 Silo Container on docking pockets with central, lever operated outlet

The unit is square in design with a conical base that has a central clam shell gate mechanism operated using the manual handle. Manufactured from high grade sheet steel with fork lift docking pockets and strengthened corners for stacking.

As standard in Pure Orange RAL 2004, Gentian Blue RAL 5010 and Anthracite Grey RAL 7016.

The following options are available at an additional cost:

- Bespoke paint (RAL number required)
- Galvanised version
- Stainless steel

Type	I	T	L	B	H	TA	A	Z	G
2052.4	300	750	1100	850	1200	300x300	500	200 x 80	125
2052.9	600	1100	1100	850	1570	300x300	500	200 x 80	150

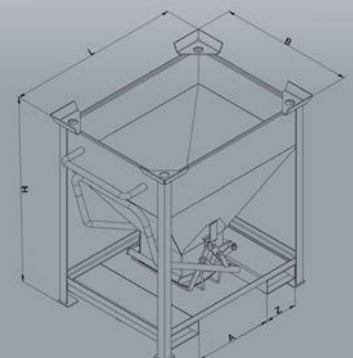



**2058 Silo Container with dispensing gate at hopper**

Manufactured from high grade sheet steel, material can be dispensed via the gate mechanism at the hopper. Fitted with fork lift docking pockets this unit can also be operated via crane using chains. The corners are reinforced for stacking and a chain provided protection against slippage.

As standard in Pure Orange RAL 2004, Gentian Blue RAL 5010 and Anthracite Grey RAL 7016.

The following options are available at an additional cost:

- Lifting lugs
- Bespoke paint (RAL number required)
- Galvanised version
- Stainless steel

Type	I	T	L	B	H	TA	A	Z	G
2058.4	300	750	1100	850	1190	300x300	500	200 x 80	120
2058.9	600	1100	1430	850	1410	300x300	600	200 x 80	175

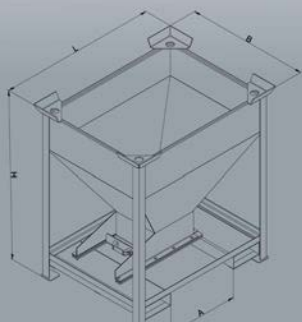

Technical modifications reserved. Figures also show extras.

**2053 Silo Container with tipping chute**

Square design container with 30 degree slope, the tipping base is fitted with hinge springs and can be operated from the drivers seat via rope pull. It can be used with a forklift or crane.

The unit is stackable and the edge sections and the fork lift docking pockets are reinforced and the chain provides protection against slippage.

As standard in Pure Orange RAL 2004, Gentian Blue RAL 5010 and Anthracite Grey RAL 7016.

The following options are available at an additional cost:

- Bespoke paint (RAL number required)
- Galvanised version
- Stainless steel

Type	I	T	L	B	H	A	Z	G
2053.4	300	750	1050	1250	750	420	200 x 80	100
2053.7	400	750	1050	1250	840	420	200 x 80	105
2053.8	500	750	1050	1250	910	420	200 x 80	110
2053.10	750	1000	1050	1250	1170	420	200 x 80	160
2053.12	1000	1500	1050	1250	1375	420	200 x 80	190

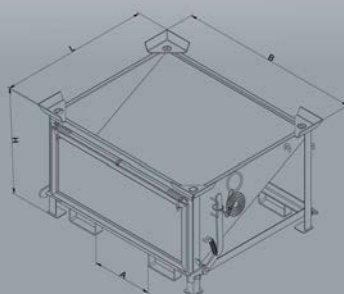

**2054 Silo Container with outlet gate**

Square design and manufactured from high grade sheet steel, the unit has a 30 degree slope with a manually operated gate at the front of the container. This allow for accurate discharge of the material. Can be operated using a forklift or crane.

The edges and fork lift pockets are reinforced for stacking and the chain provides protection against slippage.

As standard in Pure Orange RAL 2004, Gentian Blue RAL 5010 and Anthracite Grey RAL 7016.

The following options are available at an additional cost:

- Bespoke paint (RAL number required)
- Galvanised version
- Stainless steel

Type	I	T	L	B	H	TA*	A	Z	G
2054.4	300	750	1000	1200	870	300x300	375	200 x 80	85
2054.7	400	750	1000	1200	970	300x300	375	200 x 80	90
2054.8	500	750	1000	1200	1070	300x300	375	200 x 80	100
2054.10	750	1000	1000	1200	1320	300x300	375	200 x 80	150
2054.12	1000	1500	1000	1200	1560	300x300	375	200 x 80	180

TA\* = Hopper outlet bottom

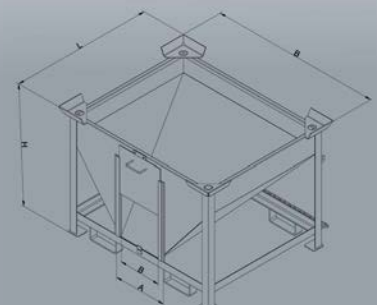

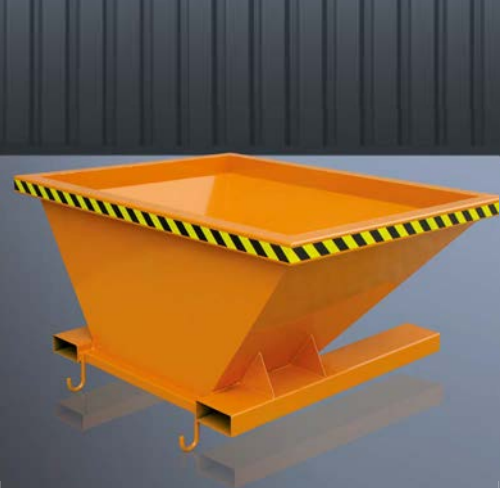

## 2056 Filling Hopper with holder for Big bags

Ideal for the targeted filling of bulk materials into Bigbags and containers, the hopper manufactured from high grade sheet steel and is designed with angled walls and an extra wide rim. It comes with 4 suspension eyes as standard as well as forklift lugs and a chain to prevent accidental slippage.

As standard in Pure Orange RAL 2004, Gentian Blue RAL 5010 and Anthracite Grey RAL 7016.

The following options are available at an additional cost:

- Lifting lugs
- Bespoke paint (RAL number required)
- Galvanised version
- Stainless steel

Type	L	B	H	A	Z	TA top	TA bottom	G
2056	1445	1775	940	810	200x80	800x600	1200x1600	230

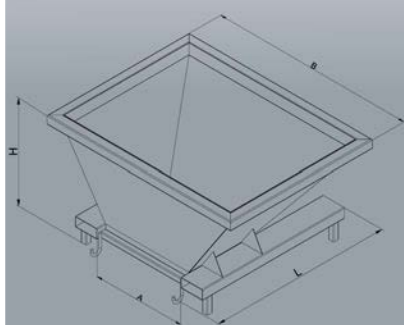

## 2057 Transfer Silo

This thick walled steel hopper is mounted on a reinforced raised base frame and offers a large collection area, ideal for the transfer of bulk material into containers and big bags. Can be transported by forklift using the docking pockets and comes with legs lugs so it can be secured to the ground.

As standard in Pure Orange RAL 2004, Gentian Blue RAL 5010 and Anthracite Grey RAL 7016.

The following options are available at an additional cost:

- Bespoke paint (RAL number required)
- Galvanised version

Type	L	B	H	H1	A	Z	TA top	TA bottom	G
2057	2210	1090	2090	1215	710	200x80	500x700	1920x900	395

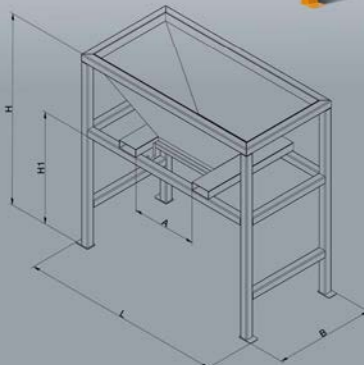

## 2061 Loading Shovel with hydraulic tipping

The shovel is fitted with a reinforced base frame designed to give balanced distribution of weight across the forklift forks. The hydraulic cylinder controls the backwards and forward tipping motion via a double joint, capable of managing heavy loads. The shape and tipping angle of the shovel mean that the unit operates at maximum efficiency during the transportation and discharge of materials.

As standard in Pure Orange RAL 2004, Gentian Blue RAL 5010 and Anthracite Grey RAL 7016.

The following options are available at an additional cost:

- Bespoke paint (RAL number required)
- Galvanised version

Type	I	T	L	B	H	G
2061.8	500	1000	1745	1050	740	248
2061.10	750	1000	1745	1250	740	260
2061.12	1000	1000	1745	1650	740	310
2061.13	1250	1500	1745	2050	740	365

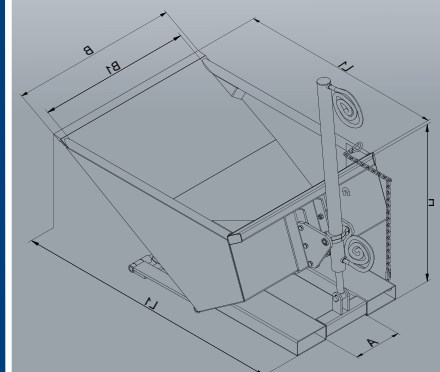

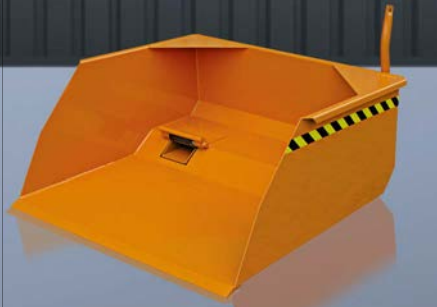

### 2062 Tipping Shovel with forklift docking pockets

The shovel attachment has been designed for high loading capacity with extra stable shovel sheet, all-round edge section, reinforced corners and special tipping ribs. The stable base frame is mounted on the fork lift docking pockets and secured against unintended slipping. The shovel can be quickly picked up with the forks and operated in any position via rope pull from the driver seat.

As standard in Pure Orange RAL 2004, Gentian Blue RAL 5010 and Anthracite Grey RAL 7016.

The following options are available at an additional cost:

- Bespoke paint (RAL number required)
- Galvanised version

Type	I	T	L	B	H	G
2062.4	300	1500	1000	1000	500	170
2062.7	400	2000	1000	1050	500	180
2062.8	500	2500	1000	1100	500	190
2062.9	600	2500	1200	1200	500	210
2062.10	750	3000	1200	1200	550	220
2062.11	800	3000	1200	1300	550	230
2062.12	1000	3000	1300	1600	650	320
2062.13	1250	3000	1300	1700	650	330
2062.14	1500	4000	1500	1800	600	380
2062.15	1750	4000	1500	1900	600	390
2062.16	2000	4000	1600	2000	650	430
2062.17	2500	4000	1600	2500	650	490

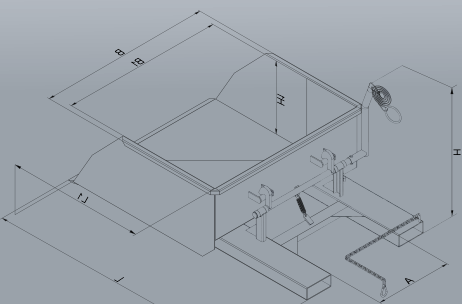

Technical modifications reserved. Figures also show extras.

### 2063 Tipping Shovel with fork push through opening

Designed with high load capacity, the unit has a triple reinforced leading edge. It is tiltable at all angles via the cable hoist at the drivers seat allowing for ease of loading. The basin of the shovel is manufactured with a waste rail and the framework is notched to secure against accidental slippage.

As standard in Pure Orange RAL 2004, Gentian Blue RAL 5010 and Anthracite Grey RAL 7016.

The following options are available at an additional cost:

- Hydraulic tipping device
- Bespoke paint (RAL number required)
- Galvanised version

Type	I	T	L	B	H	A	Z	G
2063.4	300	1500	1000	1000	500	465	150x60	170
2063.7	400	2000	1000	1050	500	465	150x60	180
2063.8	500	2500	1000	1100	500	465	150x60	190
2063.9	600	2500	1200	1100	500	465	150x60	210
2063.10	750	3000	1200	1200	550	560	150x60	220
2063.11	800	3000	1200	1300	550	560	150x60	230
2063.12	1000	3000	1300	1600	650	665	150x60	320
2063.13	1250	3000	1300	1700	650	665	150x60	330
2063.14	1500	4000	1500	1800	600	715	150x60	380
2063.15	1750	4000	1500	1900	600	650	150x60	390
2063.16	2000	4000	1600	2000	650	650	150x60	430
2063.21	2250	4000	1600	2200	650	1000	150x60	450
2063.17	2500	4000	1600	2500	650	1000	150x60	490

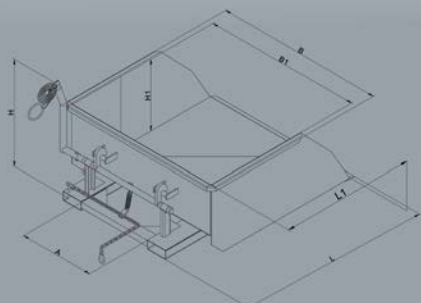

### 2064 Loading Shovel with hydraulic tipping

This shovel attachment can be used as an alternative to a digger, it provides controlled discharge of materials from any height using the dual hydraulic cylinders. Its robust design, manufactured from high grade sheet steel, has a reinforced leading edge and a safety chain for heavy loads and use at height.

As standard in Pure Orange RAL 2004, Gentian Blue RAL 5010 and Anthracite Grey RAL 7016.

The following options are available at an additional cost:

- Bespoke paint (RAL number required)
- Galvanised version

Type	I	T	L	B	H	L1	B1	H1	A	Z	G
2064.8	500	1600	1670	1230	680	1130	1200	450	420	150x65	270
2064.10	750	1600	1670	1630	680	1130	1600	450	420	150x65	300
2064.11	800	1600	1865	1580	820	1280	1550	580	420	150x65	350
2064.12	1000	2000	1865	1830	820	1280	1800	580	420	150x65	390
2064.14	1500	2500	1930	2030	900	1610	2000	650	420	200x80	430

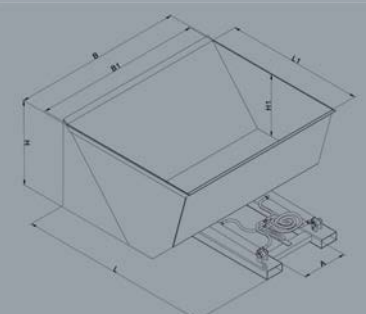

	Fork extension 2111 .....	26
	Fork extension 2112 .....	26
	Fork protection bar 2278 .....	26
	Fork lifter 2113 .....	27
	Manoeuvring aid for roll-off containers 2120 .....	27
	Shunting aid 2121 .....	27
	Snow Dozer 2071 .....	28
	Snow plough 2073.1-4 .....	28
	Snow plough 2073.5-8 .....	28
	Forklift gritter 2074 .....	29
	Forklift industrial brush head 2077 .....	29
	Wheel assembly aid 2122 .....	29





Robust. Clever. Eichinger.

# EXPAND POSSIBILITIES

More Information in German language with videos



Forklift auxiliary equipment on [eichinger-industrie.de](http://eichinger-industrie.de)



Snow clearing equipment on [eichinger-industrie.de](http://eichinger-industrie.de)

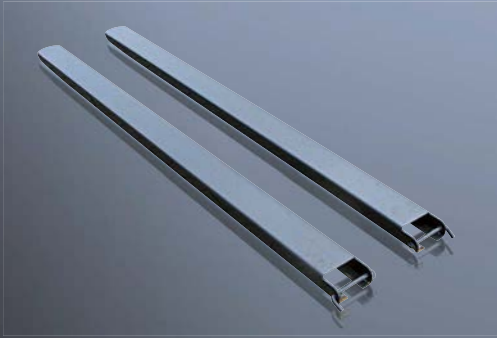

## 2111 Fork Extensions open design

Standard fork extensions for increased stability when handling awkward or large loads. The surface is finished in a durable powder coat in Anthracite Grey RAL 7016 and they are available in 5 standard sizes.

Bespoke sizes can be manufactured to order at an additional cost.

The following options are available at an additional cost:

- Bespoke paint (RAL number required)
- Galvanised version

## 2112 Fork Extensions closed design

Manufactured from quality steel in closed design allowing for quick loading of pallets. The extensions are tapered at the bevelled fork tips and a chain lock on the pins.

Finished with a durable powder coated surface in Anthracite Grey RAL 7016.

Bespoke sizes can be manufactured to order at an additional cost.

The following options are available at an additional cost:

- Powder-coated in a special RAL color
- Galvanised version

**Tip:** For static reasons, 60% of the extension should rest on the existing forks of the forklift truck.

The calculation formula is: Fork length 1,200 mm / 0.6 = max. 2,000 mm length of the fork extension.

## 2278 Fork Protection Bar

In accordance with BG regulations, the tips of the fork extensions must be covered when driving empty on public roads. They are secured by a chain and spring. The fork protection bar is provided with red and white warning markings.

As standard in Pure Orange RAL 2004, Gentian Blue RAL 5010 and Anthracite Grey RAL 7016.

The following options are available at an additional cost:

- Bespoke paint (RAL number required)
- Galvanised version

Type	Type	Länge	T	Z	T	Z	T	Z	T	Z	T	Z	T	Z	T	Z	T	Z	T	Z		
211101	211201..	1600	01	80x40	02	100x40	03	100x45	04	100x50	05	120x40	06	120x50	07	125x45	08	125x50	09	150x50	10	150x70
211102	211202..	1800	01	80x40	02	100x40	03	100x45	04	100x50	05	120x40	06	120x50	07	125x45	08	125x50	09	150x50	10	150x70
211103	211203..	2000	01	80x40	02	100x40	03	100x45	04	100x50	05	120x40	06	120x50	07	125x45	08	125x50	09	150x50	10	150x70
211104	211204..	2200	01	80x40	02	100x40	03	100x45	04	100x50	05	120x40	06	120x50	07	125x45	08	125x50	09	150x50	10	150x70
211105	211205..	2400	01	80x40	02	100x40	03	100x45	04	100x50	05	120x40	06	120x50	07	125x45	08	125x50	09	150x50	10	150x70

Order example 2111:  
Open fork extension for forklift truck with fork dimension 120 x 40 mm, 2200 mm long = 211104 05

Order example 2112:  
Closed fork extension for forklift truck with fork dimension 150 x 50 mm, 1800 mm long = 211202 09

T = Type number supplement  
Z = front fork dimension of your forklift WxH in mm

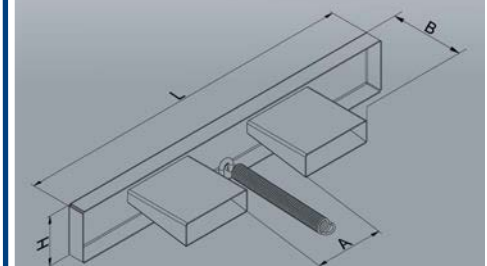
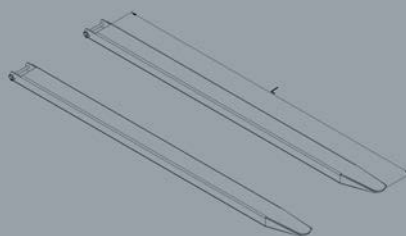
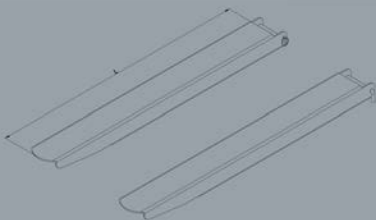

- L = Length in mm
- B = Width in mm
- H = Height in mm
- A = Prong distance in mm
- Z = Prong cross section in mm
- G = Weight in kg

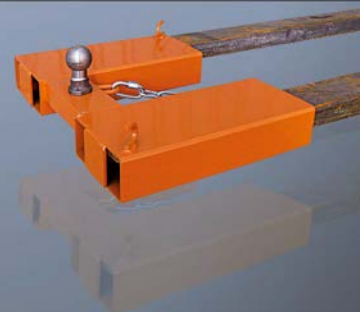

### 2113 Fork Lifter for effortless changing of fork prongs

Available in 2 versions to fit different fork prong sizes, this is a practical solution to aid lifting and changing of fork prongs manually. Designed to meet UVV standards (Accident Prevention Regulations).

As standard in Pure Orange RAL 2004, Gentian Blue RAL 5010 and Anthracite Grey RAL 7016

The following options are available at an additional cost:

- Bespoke paint (RAL number required)
- Galvanised version

Type	T	Z	G
2113.1	150	125 x 65	8
2113.2	150	150 x 65	9

T = Carrying load in kg  
Z = max. fork prong cross section in mm  
G = Weight in kg

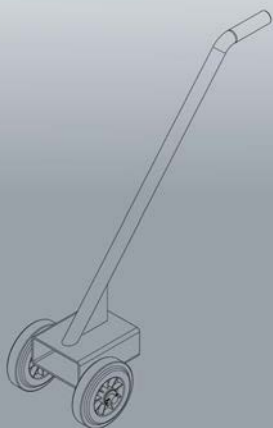

Technical modifications reserved.  
Figures also show extras.

### 2120 Manoeuvring Aid for roll-off containers

The manoeuvring aid for the forklift truck makes moving roll-off containers child's play. The solid construction is equipped with a safety device to prevent slipping off the forks. Maximum support load hook 10000 kg.

Can be used with forklift tines up to max. length 1200 mm

As standard in Pure Orange RAL 2004, Gentian Blue RAL 5010 and Anthracite Grey RAL 7016.

Type	L	B	H	A	Z	G
2120	1800	700	725	200	200 x 60	215



### 2121 Shunting Aid for trailer with ball coupling/ passenger car trailer

This practical attachment fits on the prongs of the forklift and comes complete with ball coupling (as found on standard tow bars) to easily move trailers around the site.

Available as standard in Pure Orange RAL 2004, Gentian Blue RAL 5010 and Anthracite Grey RAL 7016.

The following options are available at an additional cost:

- Bespoke paint (RAL number required)
- Galvanised version

Type	L	B	H	A	Z	G
2121	410	540	160	180	165 x 65	25

L = Length in mm  
B = Width in mm  
H = Height in mm  
A = Prong distance in mm  
Z = Prong cross section in mm  
G = Weight in kg

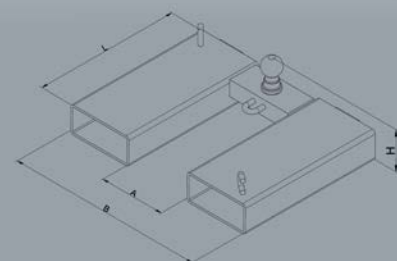



2073.1-4

2073.5-8



2073.1-4



2073.5-8

## 2071 Snow-Dozer

Manufactured from high grade sheet steel, this fork attachment has reinforced edges for clearing snow. The dozer shield can be adjusted horizontally.

Available as standard in Pure Orange RAL 2004, Gentian Blue RAL 5010 and Anthracite Grey RAL 7016.

The following options are available at an additional cost:

- Scrape Rib
- Rubber Rib
- PUR Rib
- Spring folding scraper

Type	L	B	H1	H2	B1	A	Z	G
2071.1	1930	1500	620	660	1100 - 1500	405	210x70	185
2071.2	1930	1800	620	660	1300 - 1800	405	210x70	195
2071.3	1930	2100	620	660	1500 - 2100	405	210x70	220
2071.4	1930	2400	620	660	1700 - 2400	405	210x70	235

- L = Exterior length in mm
- B = Exterior width in mm
- H1 = Height with rubber rib in mm
- H2 = Height with spring folding scraper in mm
- B1 = Clearing width "from - up to" in mm
- A = Prong distance in mm
- Z = Prong cross section in mm
- G = Weight in kg

## 2073.1-4 Snow Plough Automatic level compensation, bottom entry pocket

Manufactured from high grade sheet steel, this fork attachment is ideal for clearing snow from larger areas. This option comes with forklift bottom entry pockets, has automatic levelling and the plough shield can be adjusted horizontally.

Available as standard in Pure Orange RAL 2004, Gentian Blue RAL 5010 and Anthracite Grey RAL 7016.

The following options are available at an additional cost:

- Scrape Rib
- Rubber Rib
- PUR Rib
- Spring folding scraper

Type	L	B	H1	H2	B1	A	Z	G
<b>Bottom entry pockets</b>								
2073.1	1770	1500	620	660	1100 - 1500	400	200 x 80	220
2073.2	1770	1800	620	660	1300 - 1800	400	200 x 80	235
2073.3	1770	2100	620	660	1500 - 2100	400	200 x 80	250
2073.4	1770	2400	620	660	1700 - 2400	400	200 x 80	265

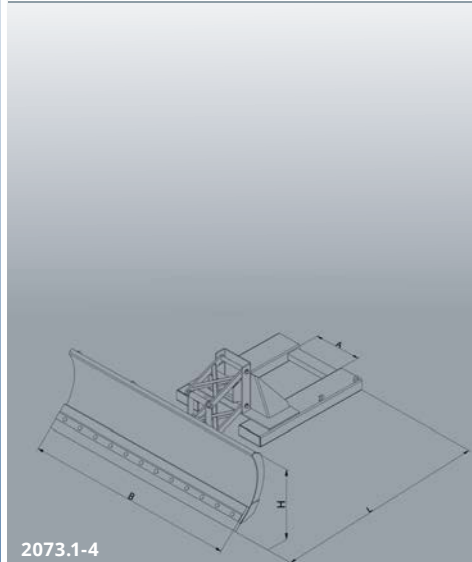

2073.1-4

## 2073.5-8 Snow Plough Automatic level compensation, top entry pocket

Manufactured from high grade sheet steel, this fork attachment is ideal for clearing snow from larger areas. This option comes with forklift top entry pockets, has automatic levelling and the plough shield can be adjusted horizontally.

Available as standard in Pure Orange RAL 2004, Gentian Blue RAL 5010 and Anthracite Grey RAL 7016.

The following options are available at an additional cost:

- Scrape Rib
- Rubber Rib
- PUR Rib
- Spring folding scraper

Type	L	B	H	H1	H2	B1	A	Z	G
<b>Top entry pockets</b>									
2073.5	1000	1500	1000	620	660	1100 - 1500	400	200 x 80	220
2073.6	1000	1800	1000	620	660	1300 - 1800	400	200 x 80	235
2073.7	1000	2100	1000	620	660	1500 - 2100	400	200 x 80	250
2073.8	1000	2400	1000	620	660	1700 - 2400	400	200 x 80	265

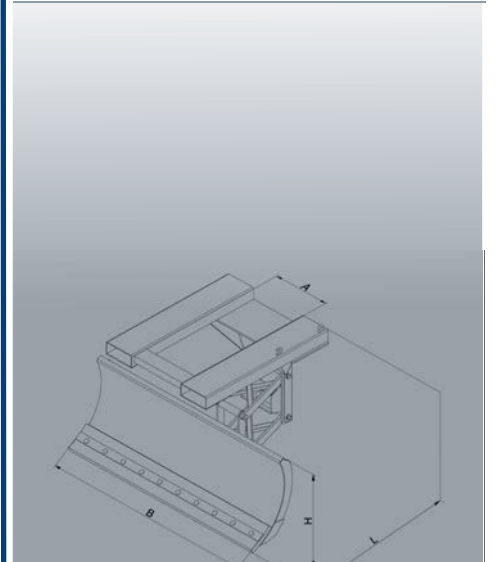

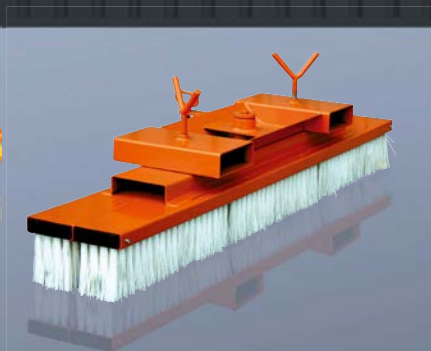
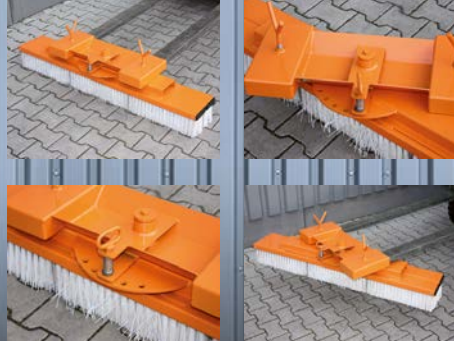

## 2074 Forklift Gritter

A hopper attachment with forklift docking pockets for spreading grit, sand and salt. Uniform distribution of material is achieved via a 'stirring' unit driven by the forklift hydraulic system and the unit has an adjustable spreading width of up to 9M to prevent 'clumping'.

The protective grid is made from zinc dipped steel and has a mesh width of 50x50x5mm.

Available as standard in Pure Orange RAL 2004, Gentian Blue RAL 5010 and Anthracite Grey RAL 7016.

The following options are available at an additional cost:

- Cover

Type	I	L	B	H	A	Z	B1	O	P	G
2074	265	1160	1090	940	665	200 x 80	9 m	15l/min	80l/min	120

- I = Volume in kg
- L = Exterior length in mm
- B = Exterior width in mm
- H = Height in mm
- A = Prongs distance in mm
- Z = Prongs dimension in mm
- B1 = Clearing width
- O = Min. oil consumption
- P = Max. output
- G = Weight in kg

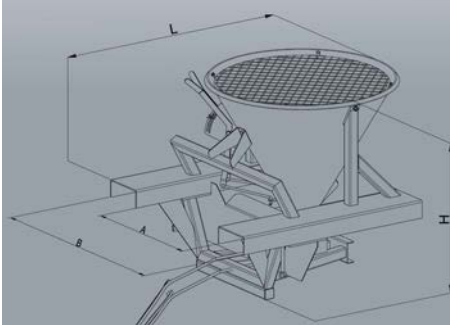

Technical modifications reserved. Figures also show extras.

## 2077 Forklift Industrial Brush Head

Manufactured from steel section tubes for strength, this industrial brush head has two brush rows and docking pockets to fit all vehicles with forklifts.

There are 3 options of brush width; 1000mm, 1500mm or 2000mm and each brush row can be individually replaced when required. The sweeping direction is left to right adjustable.

Available as standard in Pure Orange RAL 2004, Gentian Blue RAL 5010 and Anthracite Grey RAL 7016.

The following options are available at an additional cost:

- Wheeled loader attachment with forklift forks

Type	L	B	H	A	Z	G
2077.1	350	1000	390	440	160 x 55	50
2077.2	350	1500	390	440	160 x 55	60
2077.3	350	2000	390	440	160 x 55	70

- L = Exterior length in mm
- B = sweeping brush width in mm
- H = Height in mm
- A = Prong distance in mm
- Z = Prong cross section in mm
- G = Weight in kg

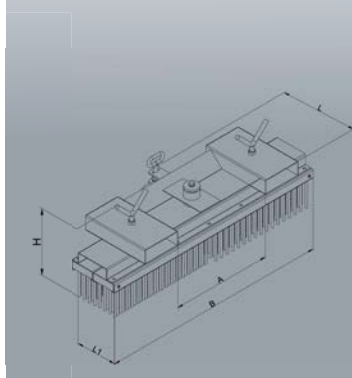

## 2122 Wheel Assembly Aid for lorry tyres etc.

Equipment to assist in changing wheels/tyres on lorries. The support bolts of the assembly aid can be adjusted to fit the tyre and the handle is also adjustable for ease of operator use. Place the wheel to be changed up to the assembly aid, loosen the wheel bolts and lift the wheel using the operator handle. Use of the unit protects from damage to the rim, bolts and brake discs.

Available as standard Pure Orange RAL 2004, Gentian Blue RAL 5010 and Anthracite Grey RAL 7016.

The following options are available at an additional cost:

- Bespoke paint (RAL number required)
- Galvanised version

Type	L	B	H	L1	W	G
2122	725	460	315	295	200-500	35

- L = Length in mm
- B = Width in mm
- H = Height in mm
- L1 = Headed dowel in mm
- W = Open width in mm
- G = Weight in kg

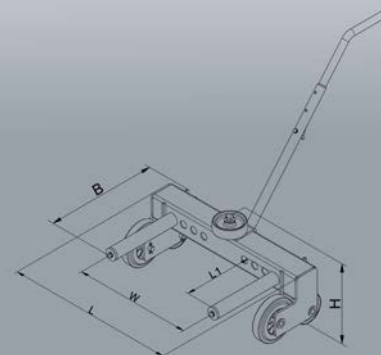



Man basket for crane and forklift 1073.1 .....32



Man basket 1073.3 .....32



Working Platform 1073.5 .....32



Working Platform 1073.6 .....33



Working Platform 1073.7 .....33



Working Platform 1073.8 .....33



Robust. Clever. Eichinger.

# WORKING HIGH UP

More Information in German language with videos

Man baskets and working platforms on [eichinger-industrie.de](http://eichinger-industrie.de)





1073.1 Version for crane and forklift operation

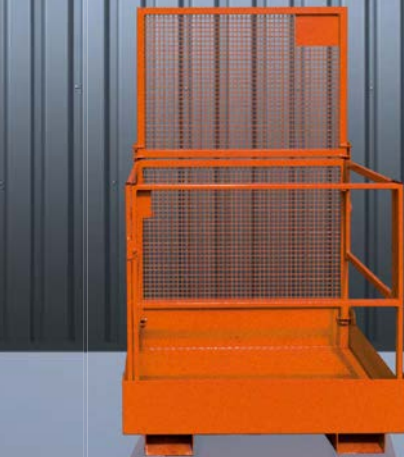

1073.3 Version for forklift operation



### 1073.1 Man Basket 2 person

Designed for use with forklift and crane, the 1073.1 is equipped with tool holding area, high kick plates to ensure items cannot be kicked over the edge, overhead protection from falling objects, four lifting lugs and side door access.

Suitable for 2 person and manufactured to official occupational safety standards.

\*\*Chain Slings are not supplied as standards and can be purchased separately\*\*

Available as standard in Pure Orange RAL 2004, Gentian Blue RAL 5010 and Anthracite Grey RAL 7016.

The following options are available at an additional cost:

- Bespoke paint (RAL number required)
- Galvanised version

	1073.1
Tare weight	230 kg
Pay load	250 kg
Permissible total weight	480 kg
Width B	1140 mm
Length L	1225 mm
Height H	2350 mm
Prongs distance	600 mm
Prongs dimensions	200 x 80 mm

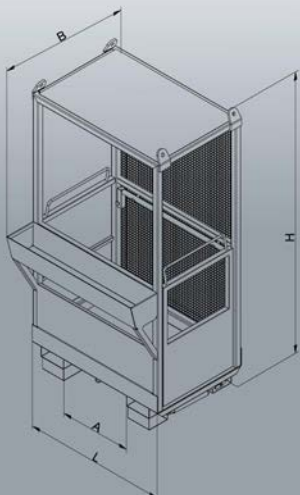

### 1073.3 Man Basket 2 person, foldable

This 2 person working platform with an extra-reinforced bottom is designed for space saving and can be folded flat for storage. For use with forklifts only the 1073.3 is manufactured to official occupational safety standards.

Available as standard in Pure Orange RAL 2004, Gentian Blue RAL 5010 and Anthracite Grey RAL 7016.

The following options are available at an additional cost:

- Bespoke paint (RAL number required)
- Galvanised version

	1073.3
Tare weight	125 kg
Pay load	250 kg
Permissible total weight	375 kg
Width B	1190 mm
Length L	1200 mm
Height H	1980 mm
Folded height	300 mm
Prongs distance	600 mm
Prongs dimensions	200 x 75 mm

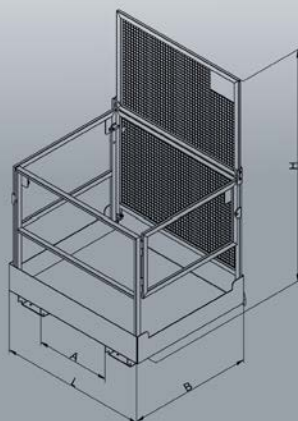

### 1073.5 Working Platform 1 person

Manufactured with a rear mesh wall and tubular side and front walls, with removable strut to allow access. The 1073.5 has a non-slip design and comes complete with locking pins to prevent slippage and a tool tray.

Built in accordance with official occupational safety standards.

Incl. 2 PPE anchor points

Available as standard in Pure Orange RAL 2004, Gentian Blue RAL 5010 and Anthracite Grey RAL 7016.

The following options are available at an additional cost:

- Powder-coated in RAL special color
- Galvanised version

	1073.5
Usable floor space	770 x 730 mm
Tare weight	95 kg
Pay load	150 kg
Permissible total weight	245 kg
Width B	910 mm
Length L	860 mm
Length with toolbox	1090 mm
Height H	2000 mm
Prongs distance	350 mm
Prongs dimensions	200 x 75 mm

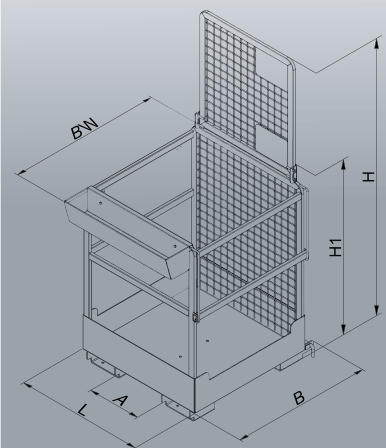





### 1073.6 Working Platform 2 person

Work platform for front loader made of robust square tube construction, closed floor pan made of non-slip material, incl. tool tray supplied as standard. Side access via sliding center strut.

Manufactured to official occupational safety standards.

Incl. 2 PPE anchor points

Available as standard in Pure Orange RAL 2004, Gentian Blue RAL 5010 and Anthracite Grey RAL 7016.

The following options are available at an additional cost:

- Powder-coated in RAL special color
- Galvanised version

1073.6	
Usable floor space	1140 x 950 mm
Tare weight	125 kg
Pay load	280 kg
Permissible total weight	405 kg
Width B	1090 mm
Length L	1200 mm
Length with toolbox	1275 mm
Height H	2000 mm
Prongs distance	610 mm
Prongs dimensions	200 x 75 mm

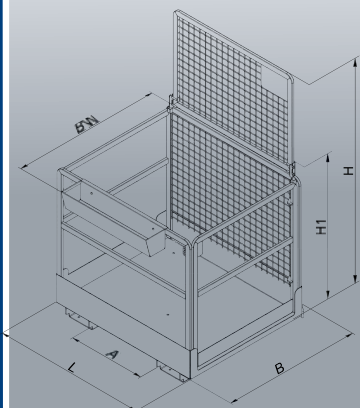

### 1073.7 Working Platform 2 person

Square tubular construction with a closed, non-slip base tray and solid kick plates to ensure items cannot fall over the edge. Comes with tool tray and side opening door for access.

Manufactured to official occupational safety standards.

Incl. 2 PPE anchor points

Available as standard in Pure Orange RAL 2004, Gentian Blue RAL 5010 and Anthracite Grey RAL 7016.

The following options are available at an additional cost:

- Powder-coated in RAL special color
- Galvanised version

1073.7	
Usable floor space	1140 x 950 mm
Tare weight	125 kg
Pay load	280 kg
Permissible total weight	405 kg
Width B	1090 mm
Length L	1200 mm
Length with toolbox	1275 mm
Height H	2000 mm
Prongs distance	610 mm
Prongs dimensions	200 x 75 mm

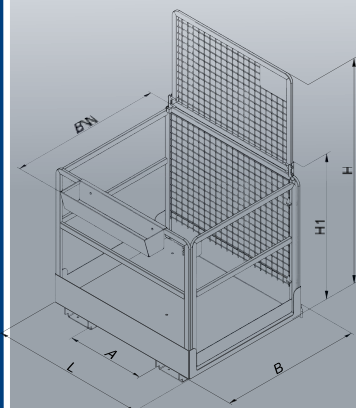

### 1073.8 Working Platform Premium

This 'Premium' version has fork pocket on 2 sides for additional manoeuvrability, 2 sided double height mesh wall for additional protection and can be used with a front loader and reach truck. With a square tubular construction the 1073.8 has a non-slip floor pan, access via a side door and a tool tray as standard.

Manufactured to official occupational safety standards.

Incl. 2 PPE anchor points

Available as standard in Pure Orange RAL 2004, Gentian Blue RAL 5010 and Anthracite Grey RAL 7016.

The following options are available at an additional cost:

- Powder-coated in RAL special color
- Galvanised version

1073.8	
Usable floor space	1140 x 950 mm
Tare weight	155 kg
Pay load	280 kg
Permissible total weight	435 kg
Width B	1290 mm
Length L	1090 mm
Length with toolbox	1265 mm
Height H	2280 mm
Prongs distance at the long side	575 mm
Prongs distance at the short side	375 mm
Prongs dimensions	200 x 75 mm

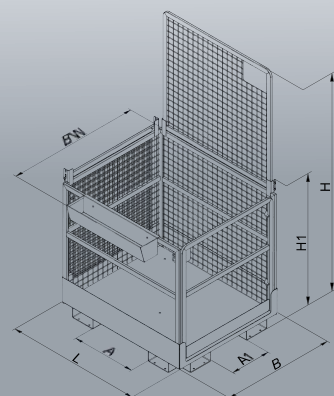

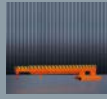

Extending jib 2081 .....36



Extending jib / telescopic loader 2082 .....36



Load hook 2084 .....37



Load hook for forklift 2085 .....37



Fork boom 2087 .....37



Hydraulic container tipper 2091 .....38

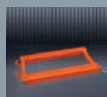

Waste bin emptier 2092 .....38



Wheely bin tipper tipper for forklift 2093 .....38



Wheely bin tipper 2094 .....38



Lattice box tipper 2095 .....39



Big bag 1096 .....39



Big bag traverse 1097 .....39



Gas bottle transport rack 1328 .....39



Robust. Clever. Eichinger.

# LIFTING LOADS

More Information in German language with videos



Lifting gear and load handling equipment on [eichinger-industrie.de](http://eichinger-industrie.de)



## 2081 Extending Jib telescopic

The 2081 has been designed to convert a standard forklift truck into a universal mobile crane unit. Available in two load capacities, 2500kg and 5000kg the unit has 7 extendable settings and comes with swivel load hooks and is secured with bolt to prevent unintentional slippage.

Available as standard in Pure Orange RAL 2004, Gentian Blue RAL 5010 and Anthracite Grey RAL 7016.

The following options are available at an additional cost:

- Bespoke paint (RAL number required)
- Galvanised version

Type	T	B	H	W-W1	A	Z	G
2081.1	2500	520	430	670 - 3665	110	190 x 90	150
2081.2	5000	520	510	670 - 3665	110	190 x 90	180

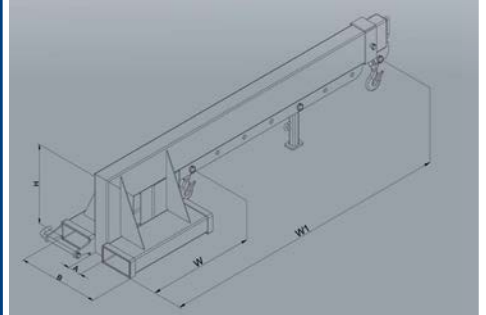

## 2082 Extending Jib telescopic and height-adjustable

The 2082 has been designed to convert a standard forklift truck into a universal mobile crane unit. Available in two load capacities, 2500kg and 5000kg, the unit has a 3 step height adjustable function to 45 degrees as well as 7 extendable settings. It comes with swivel load hooks and is secure with a bolt to prevent unintentional slippage.

Available as standard in Pure Orange RAL 2004, Gentian Blue RAL 5010 and Anthracite Grey RAL 7016.

The following options are available at an additional cost:

- Bespoke paint (RAL number required)
- Galvanised version

Type	T	B	H	W-W1	H1 (0-45°)	A	Z	G
2082.1	2500	540	645	740 - 3735	195 - 2490	130	190 x 90	220
2082.2	5000	540	645	740 - 3735	130 - 2435	130	190 x 90	250

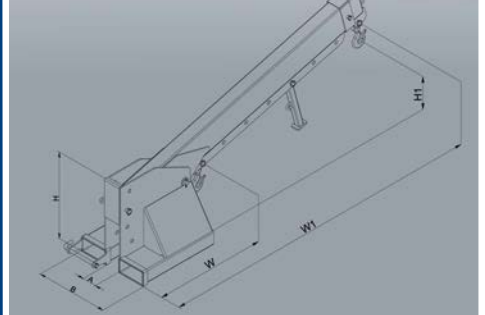

- Legend for abbreviations in the tables
- T = Load cap. in kg
  - L = Length in mm
  - B = Width in mm
  - H = Height in mm
  - W = Extendable range W - W1
  - H1 = Adjustable angle of inclination (0-45°)
  - A = Prongs distance in mm
  - Z = Prongs dimension in mm
  - K = Tipping angle
  - G = Weight in kg

2084.2-4

2084.1



## 2084 Fork Mounted Load Hook

1 or 2 fork prong attachment

The 2084 enables the conversion of any forklift into a simple mobile crane unit allowing the lifting of items by chains and slings in a secure and safe manner. The 2084 is secured to the fork lift via a heel pin.

Available as standard in Pure Orange RAL 2004, Gentian Blue RAL 5010 and Anthracite Grey RAL 7016.

The following options are available at an additional cost:

- Bespoke paint (RAL number required)
- Galvanised version
- Options for different load capacities

Type	T	L	B	H	A	Z	G
<b>For 1 fork of a forklift</b>							
2084.1	1000	400	210	510	-	200x80	14,5
<b>For 2 forks of a forklift</b>							
2084.2	2000	940	645	270	300	160x65	50
2084.3	3000	940	735	270	300	200x80	70
2084.4	5000	940	735	320	300	200x80	75



## 2085 Fork Mounted Load Hook

Two fork prong attachment

Enable to conversion of a forklift into a simple mobile crane unit – this version is for use with 2 fork prongs only. Complete with swivel hook in ensures central load distribution across both forklift prongs. It is secured to the fork lift via a side mounted wing screw.

Available as standard in Pure Orange RAL 2004, Gentian Blue RAL 5010 and Anthracite Grey RAL 7016.

The following options are available at an additional cost:

- Bespoke paint (RAL number required)
- Galvanised version
- Options for different load capacities

Type	T	L	B	H	HB	A	Z	G
2085.1	2500	790	180	130	270	300	160x60	30
2085.2	5000	890	190	150	330	300	200x80	45

Legend for abbreviations in the tables

- T = Load capacity in kg
- L = Length in mm
- B = Width in mm
- H = Height in mm
- HB = Height with hook in mm
- A = Prongs distance in mm
- Z = Prongs dimension in mm
- G = Weight in kg

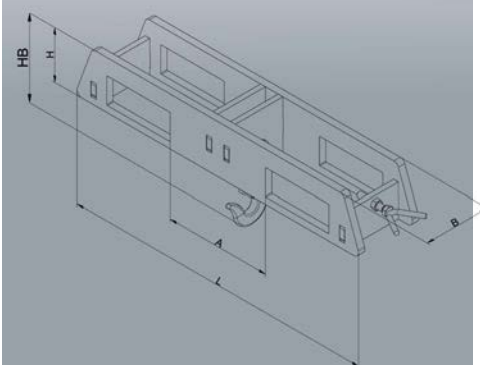

## 2087 Fork Boom

Two fork prong attachment

Specifically designed for transportation of tubes, hollow bodied equipment, carpet rolls etc, the 2087 can be supplied in different lengths and a choice of load capacities.

Available as standard in Pure Orange RAL 2004, Gentian Blue RAL 5010 and Anthracite Grey RAL 7016.

The following options are available at an additional cost:

- Bespoke paint (RAL number required)
- Galvanised version
- Options for different load capacities

Type	T	Ø	L	B	H	L1	A	Z	G
2087.1	1000	85	2800	840	490	2000	400	200 x 80	150
2087.2	1000	85	3800	840	490	3000	400	200 x 80	180
2087.3	1500	85	2800	840	490	2000	400	200 x 80	170
2087.4	1500	85	3800	840	490	3000	400	200 x 80	200
2087.5	2000	110	2800	840	490	2000	400	200 x 80	205
2087.6	2000	110	3800	840	490	3000	400	200 x 80	255
2087.7	2500	110	2800	840	490	2000	400	200 x 80	225
2087.8	2500	110	3800	840	490	3000	400	200 x 80	275

Legend for abbreviations in the tables

- T = Load capacity in kg
- Ø = Ram diameter in mm
- L = Length in mm
- B = Width in mm
- H = Height in mm
- L1 = Ram length in mm
- A = Prongs distance in mm
- Z = Prongs dimension in mm
- G = Weight in kg

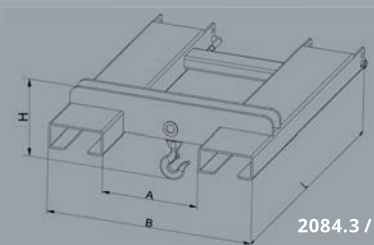
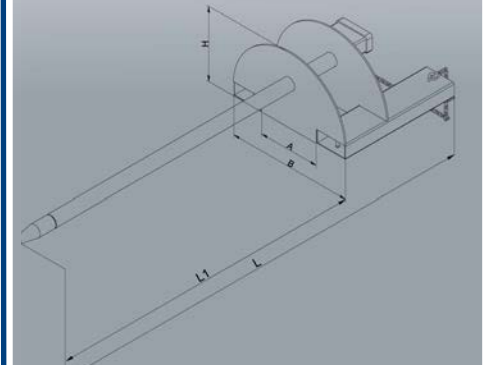

2084.3 / 2084.4

Technical modifications reserved. Figures also show extras.



## 2091 Container Tipper hydraulic for container and silos with forklift brackets

The 2091 has been designed to facilitate the movement of containers and silos using a fork lift. It is equipped with a hydraulic, rotating mechanism providing accurate release of the material. This will work with all containers that have docking pockets and the unit can be rotated up to 130 degrees at a left handed angle.

Available as standard in Pure Orange RAL 2004, Gentian Blue RAL 5010 and Anthracite Grey RAL 7016.

The following options are available at an additional cost:

- Bespoke paint (RAL number required)
- Galvanised version

Type	T	L	B	H	X	Y	A	Z	K	G
2091	1500	2420	1190	445	120	60	480	200x80	130° to the left	275

Adjustment of forks  
W = 525, 725, 925, 1125 mm

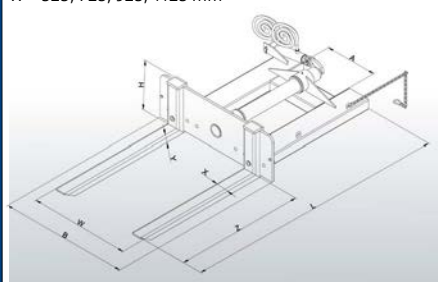

## 2092 Waste bin emptier

The refuse bin emptier in solid steel construction for mechanical collection of household bins via the front hooks; easy operation and transport using a forklift truck. Secured with a chain to prevent accidental slipping.

Available as standard in Pure Orange RAL 2004.

The following options are available at an additional cost:

- Bespoke paint (RAL number required)
- Galvanised version

Type	T	I	L	B	H	A	Z	G
2092	600	80-240	1000	1020	300	660	170x70	42

## 2093 Wheelie Bin Tipper household bins

Designed for use with household style bins, the 2093 is ideal for emptying and washing. The tipping unit is manufactured with reinforced steel sections with integrated forklift docking pockets with a twist free base and frame. The tipping mechanism is unlocked via a rope pull operated from the drivers seat. Two hooks attach the waste bin automatically at the fixing point. Suitable for all vehicles with fork prongs.

Available as standard in Pure Orange RAL 2004, Gentian Blue RAL 5010 and Anthracite Grey RAL 7016.

The following options are available at an additional cost:

- Bespoke paint (RAL number required)
- Galvanised version

Type	T	I	L	B	H	A	Z	K	G
2093.1	600	80 / 120	1000	930	950	570	170 x 70	180°	74
2093.2	600	240	1000	1020	1065	660	170 x 70	180°	77

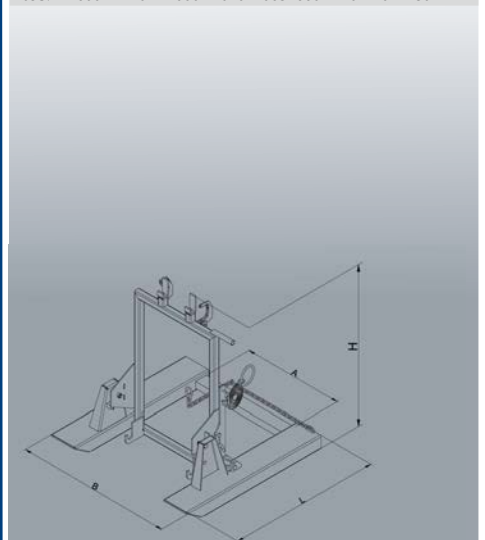

## 2094 Wheelie Bin Tipper large/industrial bins and wheeled waster containers

For secure lifting, transportation and emptying of large industrial and wheeled waste containers, the 2094 facilitates easy movement, emptying and cleaning within a factory or site environment using a forklift. Two foldable arms securely attach the 2094 to the forklift and the covers of the containers are held open via a steel rope, while the hydraulic tipping mechanism tilts the unit using controllable throttle valves. This is suitable for use with all vehicle with fork prongs.

Available in a galvanised finish as standard.

The following options are available at an additional cost:

- in pure orange RAL 2004, gentian blue RAL5010, anthracite gray RAL7016.
- Bespoke paint (RAL number required)

Type	T	L	B	H	L1	B1	A	Z	K	G
2094	600	1890	1590	900	900	600	110	200 x 80	135°	175

Legend for abbreviations in the tables

- T = Load capacity in kg
- L = Length in mm
- B = Width in mm
- H = Height in mm
- A = Prongs distance in mm
- Z = Prongs dimension in mm
- K = Tipping angle
- G = Weight in kg

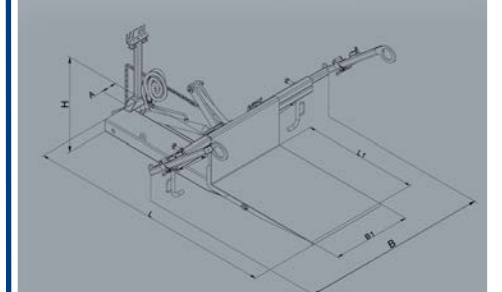



**2095 Lattice Box Tipper**  
euro standard mesh stillages

Made for the transportation, emptying and washing of mesh walled stillages (Euro standard). The 2095 has integrated fork pockets and is suitable for use with all vehicles with fork prongs. The two tensioning hooks lock automatically as soon as the forklift hydraulic mechanism is in use.

Available in a galvanised finish as standard.

The following options are available at an additional cost:

- in pure orange RAL 2004, gentian blue RAL5010, anthracite gray RAL7016.
- Bespoke paint (RAL number required)

Type	T	L	B	H	A	Z	K	G
2095	500	1850	1170	1050	110	200 x 80	135°	190

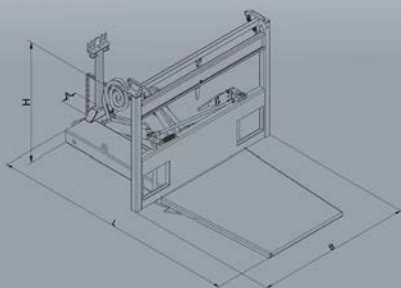

Technical modifications reserved. Figures also show extras.

**1097 Big Bag Spreader Beam**

Constructed from heavy duty steel for transportation of big bags by forklift or hoist. The spacing of the bearing pins ensures that the big bag slings are protected from long term wear.

Available as galvanised on request.

Type	T	L	B	HB*	A	Z	G
1097.1	1000	930	915	440	280	190x90	68
1097.2	1500	930	915	440	280	190x90	72
1097.3	2000	930	915	440	280	190x90	80
1097.4	3000	930	915	455	280	190x90	92

**1096 Big Bag**

Rugged 'bag' for the transportation and storage of coarse and fine bulk material with and without dust content. Manufactured from polypropylene fibre with seam seals for extra durability, this bag is suitable for frequent re-use.

Type	T	T	B	H	HB*	G
1096.1	1000	900	900	1200	1500	1
1096.2	1250	900	900	1200	1500	1
1096.3	1500	900	900	1200	1500	1

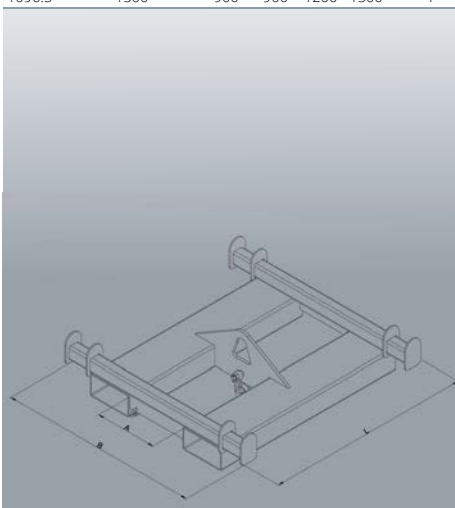

**1328 Craneable Gas Bottle Carrier**

Of robust steel tubular design, the 1328 is available in various sizes to accommodate a variety of gas bottles and provides a secure method of moving bottled product around the site.

Supplied as standard with both crane lift point and forklift pockets to increase flexibility, the unit has solid steel 'docking points' to fit large or small bottles.

The below bottle sizes are available:

- Cylinders with Ø 220mm
- Cylinders with Ø 300mm
- Cylinders with Ø 320mm

The following options are available at an additional cost:

- Bespoke Paint (RAL number required)
- Galvanised version

Type	NO*	L	B	H	A	Z	G
1328.1	4	900	635	2000	550	60x160	120
1328.2	6	1200	635	2000	790	60x160	150

- NO = Number of barrels
- L = Length in mm
- B = Width in mm
- H = Height in mm
- A = Prong distance in mm
- Z = Prong cross section in mm
- G = Weight in kg

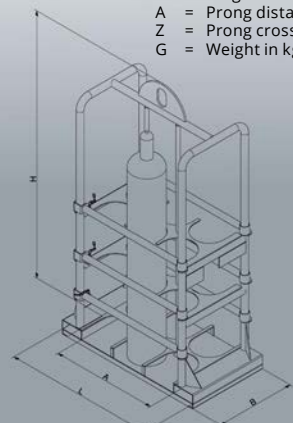



Transport box 1058 .....42



Material transport box 1058.9 .....42



Tool box 1210 .....42



Tool box 1211 .....42



Stacking pallet 1314 .....43



Mesh box stacking pallet 1315 .....43



Solid wall stacking pallet 1316 .....43



Battery charging station 2116 .....44



Transport rack for chargers 2117 .....44



Big bag holder 3039 .....44



Heavy-duty drawer shelving 2280 .....45



Honeycomb shelving 2282 .....45



Universal container 2031 .....46



Picking platform 2097 .....46

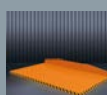

Collection platform 2098 .....46



Panel transport trolley 1104 .....47



All-terrain pallet truck 1106..... 47



Sack truck 1108 .....47





Robust. Clever. Eichinger.

# COLLECT & STORE

More Information in German language with videos



Storage systems on [eichinger-industrie.de](http://eichinger-industrie.de)



Transport systems on [eichinger-industrie.de](http://eichinger-industrie.de)



## 1058 Heavy Duty Carrying Cage

Sturdy, tubular framed goods cage, with mesh walls and checker plate floor. Will fit Euro and Industrial sized pallets. Comes complete with docking pockets for use with a forklift and lifting lugs for use with a crane. Chains sold separately.



Available as standard in Pure Orange RAL 2004, Gentian Blue RAL 5010 and Anthracite Grey RAL 7016.

Type	L	B	H	L1	B1	H1	A	Z	G
1058.1	1280	1260	1100	1155	1170	1000	600	200x75	160
1058.2	2550	1260	1100	2350	1125	1000	650	200x75	380

Any special size available



L = Outer length in mm  
 B = Outer width in mm  
 H = External height in mm  
 L1 = inside length in mm  
 B1 = inside width in mm  
 H1 = Inside height in mm  
 A = Tine spacing in mm  
 Z = Tine cross-section in mm  
 G = Dead weight in kg

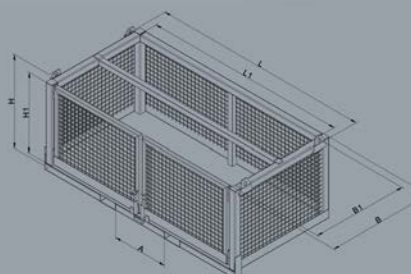

## 1058.9 Heavy Duty Carrying Cage with Ramp

Sturdy, tubular framed goods cage, with mesh walls, folding access ramp and checker plate floor and ramp. The 1058.9 has a maximum load capacity of 1500kg and will fit Euro pallets. Comes with forklift docking pockets and lifting lugs for use with a crane. Chains are sold separately.

Available as standard in Pure Orange RAL 2004, Gentian Blue RAL 5010 and Anthracite Grey RAL 7016.

Type	L	B	H	L1	B1	H1	A	Z	G
1058.9	1280	1260	1100	1155	1170	1000	600	200x75	160

Any special size available

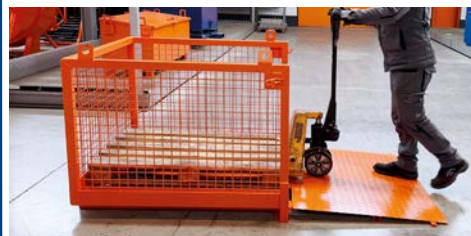

L = Outer length in mm  
 B = Outer width in mm  
 H = External height in mm  
 L1 = inside length in mm  
 B1 = inside width in mm  
 H1 = Inside height in mm  
 A = Tine spacing in mm  
 Z = Tine cross-section in mm  
 G = Dead weight in kg

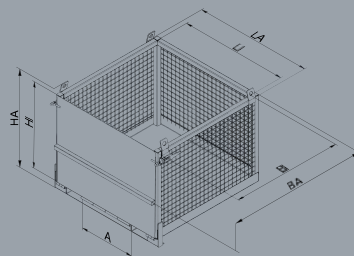

## 1210 Storage Box steel

A robust, safe storage box for tools, the 1210 is manufactured from sheet steel. With 6 feet providing ground clearance to allow movement via forklift it also boasts crane hooks a checker plate lid and padlock eyelets as standard.

Available as standard in Pure Orange RAL 2004, Gentian Blue RAL 5010 and Anthracite Grey RAL 7016.

The following options are available at an additional cost:

- Bespoke Paint (RAL number required)
- Galvanised version

Type	I	T	L	B	H	U	G
1210.1	300	300	1120	610	800	100	68
1210.2	500	300	1120	1110	800	100	100
1210.3	600	400	1920	710	800	100	128

## 1211 Storage Box aluminium

An aluminium storage box for the safe storage of tools, six feet provide a ground clearance for use with a forklift truck. Comes complete with crane hooks, checker plate lid and padlock eyelets as standard.

Type	T	I	L	B	H	U	G
1211.1	300	300	1120	610	800	100	26
1211.2	600	500	1120	1110	800	100	40
1211.3	400	600	1920	710	800	100	50

T = Load capacity in kg  
 I = Capacity in l  
 L = Length in mm  
 B = Width in mm  
 H = Height in mm  
 U = Underride height in mm  
 G = Tare weight in kg

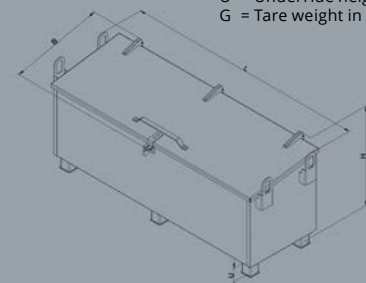



Bespoke sizes on demand

1316 Material box with welded partitions, optionally in hot-dip galvanised design



1315.4-8  
One drop side  
1/3 (long side)

1316.4-8  
One drop side  
1/3 (long side)

## 1314 Stacking Stillage

With profiled corner posts, wide feet and stacking pockets with crane lugs. The FE 1314 has a load capacity of 2000kg and a ground clearance of 140mm. Can be used in combination with FE 1315 and FE 1316.

Available as standard lacquered in Chocolate Brown RAL 8017.

The following options are available at an additional cost:

- Bespoke paint (RAL number required)
- Galvanised version
- Bespoke Sizes

Type	L	B	H	H1	H2	U	G
1314.1	1000	800	750	600	70	140	28
1314.2	1200	800	750	600	70	140	30
1314.3	1500	800	750	600	70	140	32
1314.4	1500	1000	750	600	70	140	33

Length and width = exterior dimensions

- L = Length in mm
- B = Width in mm
- H = Height in mm
- H1 = Effective depth in mm
- H2 = Height of extension in mm
- U = Ground clearance in mm
- G = Weight in kg

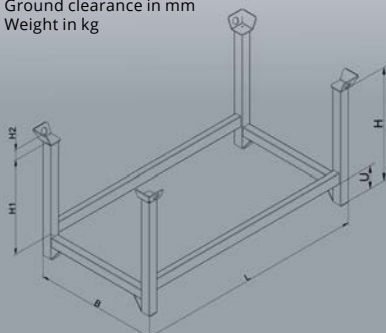

Technical modifications reserved. Figures also show extras.

## 1315 Stacking Stillage mesh walled

With profiled corner posts, wide feet and wide stacking pockets, the FE 1315 has wire meshed side walls (lattice bars 50mm x 50mm). It has a 1.5mm corrugated sheet metal base and comes complete with crane lugs for use with a crane as well as a forklift. It has a load capacity of 1500kg, ground clearance of 100mm and can be used in combination with the FE 1314 and FE 1316.

Model numbers 1315.5 - 1315.8 are available with a drop side (1/3).

As standard in Chocolate Brown RAL 8017.

The following options are available at an additional cost:

- Bespoke paint (RAL number required)
- Galvanised version
- Bespoke Sizes

Type	L	B	H	H1	H2	U	G
1315.1	1000	800	750	645	70	100	57
1315.2	1200	800	750	645	70	100	63
1315.3	1500	800	750	645	70	100	72
1315.4	1500	1000	750	645	70	100	76

One drop side 1/3 (long side)

1315.5	1000	800	750	645	70	100	61
1315.6	1200	800	750	645	70	100	67
1315.7	1500	800	750	645	70	100	76
1315.8	1500	1000	750	645	70	100	80

Length and width = exterior dimensions

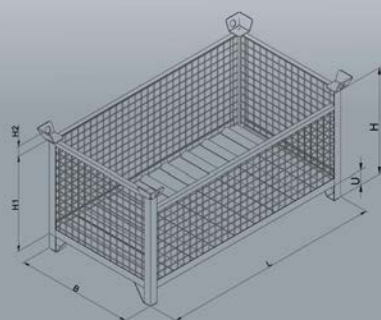

## 1316 Stacking Stillage solid walled

With profiled corner posts, wide feet and press fitted stacking pockets, the FE 1316 has solid corrugated steel side walls with rib reinforcement, as well as a solid corrugated steel base. Complete with lifting lugs for use with a crane as well as a forklift, the FE 1316 can be used in combination with the FE 1314 and FE 1315 and has a load capacity of 1500kg with a ground clearance of 100mm.

Model number 1316.5 - 1316.8 are available with a drop side (1/3).

As standard in Chocolate Brown RAL 8017.

The following options are available at an additional cost:

- Cover
- Bespoke paint (RAL number required)
- Galvanised version
- Bespoke Sizes

Type	L	B	H	H1	H2	U	G
1316.1	1000	800	750	645	70	100	60
1316.2	1200	800	750	645	70	100	65
1316.3	1500	800	750	645	70	100	73
1316.4	1500	1000	750	645	70	100	81

One drop side 1/3 (long side)

1316.5	1000	800	750	645	70	100	66
1316.6	1200	800	750	645	70	100	71
1316.7	1500	800	750	645	70	100	79
1316.8	1500	1000	750	645	70	100	81

Length and width = exterior dimensions

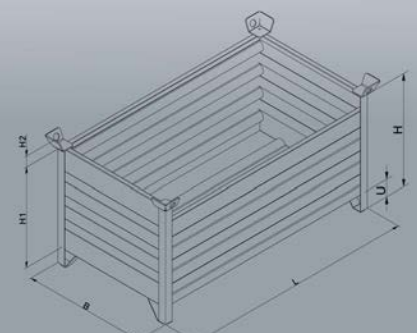



## 2116 Battery Charging Station in line with GroLa BG and VdS- information sheet 2259

Designed with a flat back to be secured against a wall, the 2116 allows for easy charging in one visible location. Complete with all necessary safety precautions and signage, it provides the following:

- Folding shelf for placing charging devices and batteries
- Storage for gloves, protective glasses
- Eye rinsing bottle
- Warning signs
- Fault current protective device >30 mA
- 2 earthed safety sockets 16A 230V
- Cable brackets

Available as standard in Pure Orange RAL 2004, Gentian Blue RAL 5010 and Anthracite Grey RAL 7016.

The following options are available at an additional cost:

- CEEForm socket 16A 400V
- CEEForm socket 32A 400V
- 6kg fire extinguisher and bracket
- Water container bracket

Type	L	B	H	H1	G
2116	1010	440	1810	1000	65

- L = Length in mm
- B = Width in mm
- H = Height in mm
- H1 = Table height in mm
- G = Weight in kg

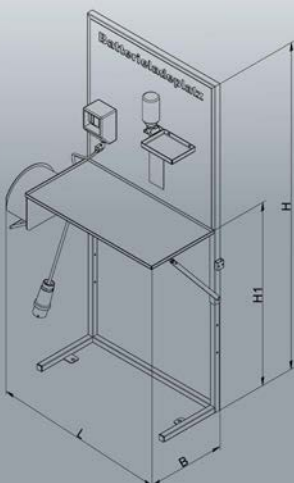

## 2117 Charger Transport Cabinet

Ideal for transportation and storage of forklift batteries, the 2117 has a roof and rear wall made of sheet steel and wire mesh side walls. The battery is secured to the rear wall via lashing straps connected to welded on eyelets. It comes with a cable suspension on the left hand side wall and can be stacked 3 high for storage when fully loaded.

Can be used with a forklift and crane. Includes as standard:

- 2 fastening eyelets and 1 lashing strap
- Cable Suspension
- Rear wall cable grommet

Available as standard in Pure Orange Ral 2004, Gentian Blue RAL 5010 and Anthracite Grey RAL 7016.

The following options are available at an additional cost:

- Aquamatic version with water tank holder, hose reel and vertical bar with filling platform
- Lockable hinged doors

Type	T	L	B	H	H1	H2	U	A	Z	G
2117	1000	1110	600	800	600	75	100	560	200x80	78

### Any special size available

- T = Load capacity in kg
- L = External length in mm
- B = External width in mm
- H = External height in mm
- H1 = Internal height in mm
- H2 = Crane eye height in mm
- U = Underride height in mm
- A = Fork spacing in mm
- Z = Fork cross-section in mm
- G = Dead weight in kg

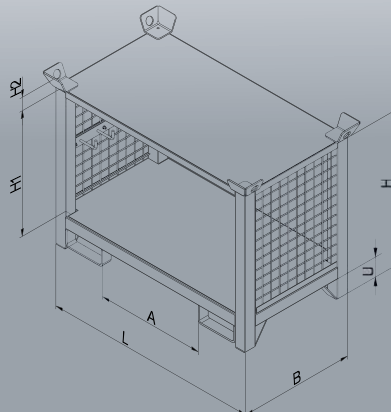

## 3039 Big Bag Support

Galvanised, sheet steel support frame designed to fit big bags. The 3039 has height adjustable corner profiles that can tension the bag to hold bulk wet material. Complete with a collection tray, with drains, for liquid leakage and overspill.

Comes with docking pockets and lifting lugs for use with a forklift and crane.

Galvanised as standard.

The following options are available at an additional cost:

- 2 fixed and 2 swivel castors
- lifting lugs for crane lifting

Type	Content	L	B	H	H1	U	G
3039	375	1200	1200	1585	510	150	190
<b>Transport dimensions</b>							
3039	375	1200	1200	690			190

- L = Length in mm
- B = Width in mm
- H = Height in mm
- H1 = Height collecting tray
- U = Underclearance in mm
- G = Weight in kg

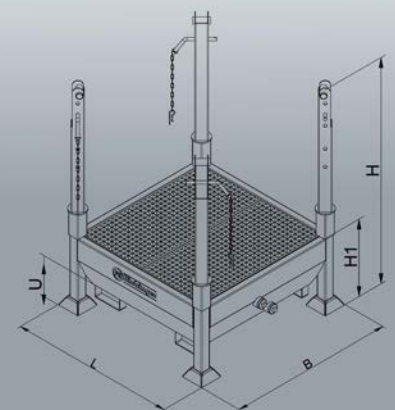

Technical modifications reserved.  
Figures also show extras.



## 2280 Heavy Load Rack with pull out shelving

Steel, sectional heavy duty racking unit designed to accommodate heavy loads. The shelving height is fully adjustable and has runners and handles to allow the shelving to pull out for easy access. Each shelf has a reinforced leading edge for forklift loading.

Available as standard in Pure Orange RAL 2004, Gentian Blue RAL 5010 and Anthracite Grey RAL 7016.

The following options are available at an additional cost:

- Bespoke paint (RAL number required)
- Galvanised version
- Bespoke Sizes

Type	T	B	W	H	B1	W1	W2
2280.1	1000	850	900	2010	805	845	770
2280.2	1000	850	1100	2010	805	1045	970
2280.3	1000	850	1300	2010	805	1245	1170
2280.4	1000	1050	900	2010	1005	845	770
2280.5	1000	1050	1100	2010	1005	1045	970
2280.6	1000	1050	1300	2010	1005	1245	1170
2280.7	1000	1250	900	2010	1205	845	770
2280.8	1000	1250	1100	2010	1205	1045	970
2280.9	1000	1250	1300	2010	1205	1245	1170

T = Load capacity in kg  
 B = Clearfield width in mm  
 W = Rack depth in mm  
 B1 = Usable width in mm  
 W1 = Usable depth in mm  
 W2 = Extendable depth in mm

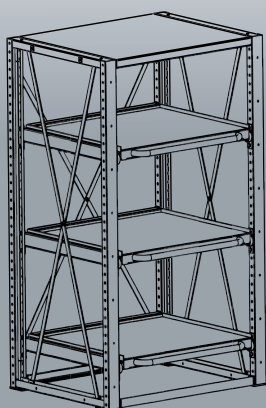

## 2282 Honeycomb Shelving

Designed to accommodate the storage of long blanks and bars, this modular deep set shelving has a standard storage length of 3010mm. Each standard unit consists of 16 spaces per item but different configurations can be supplied with maximum length of 6000 mm. Modules can be stacked up to 2 metres high.

Available as standard in Pure Orange RAL 2004, Gentian Blue RAL 5010 and Anthracite Grey RAL 7016.

The following options are available at an additional cost:

- Bespoke paint (RAL number required)
- Cantilevered shelving
- Bespoke Sizes

Type	F	A	L/T	B	H	Shelf dim.	T/R	T/F	G
2282.1	16	4x4	3010	1000	1000	220x3000x215	5120	320	450
2282.2	20	4x5	3010	1000	1000	220x3000x170	6400	320	480
2282.3	24	4x6	3010	1000	1000	220x3000x140	7680	320	550
2282.4	25	5x5	3010	1000	1000	175x3000x170	6500	260	560
2282.5	30	5x6	3010	1000	1000	175x3000x140	7800	260	590
2282.6	36	6x6	3010	1000	1000	145x3000x140	7560	210	620
2282.7	48	6x8	3010	1000	1000	145x3000x105	10080	210	720
2282.8	64	8x8	3010	1000	1000	105x3000x105	10240	160	820

F = Number of shelves  
 A = Arrangement of shelves  
 L/T = Length or depth in mm  
 B = Width in mm  
 H = Height in mm  
 T/R = Load capacity of the shelf in kg  
 T/F = Load capacity of a shelf in kg  
 G = Tare weight in kg

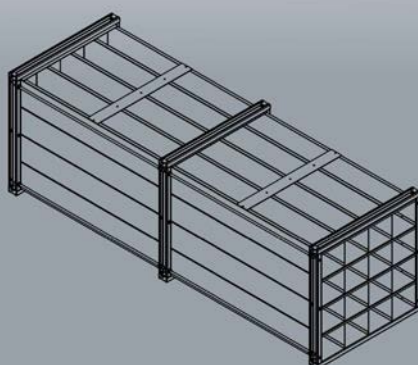

## 2282.50 Cantilever rack for honeycomb shelving



Cantilevered shelving as an extension of honeycomb rack 2282 consisting of three uprights with three support arms each, which are equipped with a 50 mm high roll-off protection.

Note: Floor anchoring is required!

Standard in anthracite grey RAL7016

Optionally available in

- Powder-coated in a special RAL colour
- Special sizes

Type	L/T	B	H	Shelf dim.	T/R	T/F	G
2282.50	150	660	1000	50x500x230	1000	330	80

L/T = Length or depth in mm  
 B = Width in mm  
 H = Height in mm  
 T/R = Load capacity per upright in kg  
 T/F = Load capacity per cantilever arm in kg  
 G = Tare weight in kg



This model is offered in normal scope of delivery without any rollers

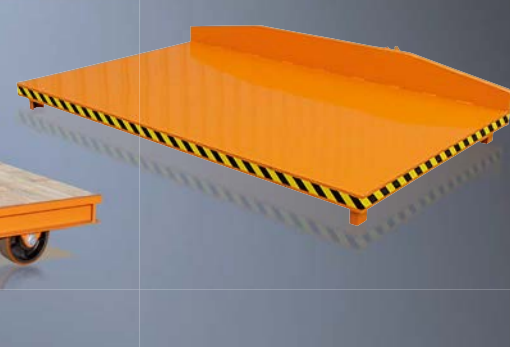

## 2031 Universal Skip

The 2031 is ideal for general use in industry or construction. Integrated fork pockets and crane lifting points make this unit easy to move around sites. The unit can also be supplied with heavy duty castors as an additional option. The unit is stackable and sloped sided design prevents tilting and is fully tested and certified to current safety standards.

Available as standard in Pure Orange RAL 2004, Gentian Blue RAL 5010 and Anthracite Grey RAL 7016.

The following options are available at an additional cost:

- Heavy duty castors (2 fixed and 2 Swivel)
- Multi part galvanised cover
- Bespoke Paint (RAL number required)
- Galvanised version
- Stainless Steel
- Hydraulic Tipping version 2091

Type	I	T	L	B	H	L1	B1	H1	A	Z	G
2031.4	300	1000	1040	1210	520	930	1135	330	560	200x70	100
2031.8	500	1000	1040	1210	730	930	1135	550	560	200x70	120
2031.10	750	1500	1040	1210	980	930	1135	800	560	200x70	145
2031.12	1000	2000	1040	1210	1300	930	1135	1120	560	200x70	195

Legend for abbreviations in the tables

- I = Volume in litre
- T = Load capacity in kg
- L = Exterior length in mm
- B = Exterior Width in mm
- H = Exterior Height in mm
- L1 = Interior length in mm
- B1 = Interior width in mm
- H1 = Interior height in mm
- A = Prongs distance in mm
- Z = Prongs dimension in mm
- G = Weight in kg

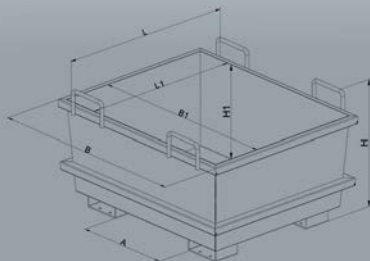

## 2097 Commissioning Platform

A hard wearing loading platform made with a sectional steel frame that can be easily manoeuvred around site via use of the slewing ring. The base is made from pine, ensuring a non-slip working area.

Available as standard in Pure Orange RAL 2004, Gentian Blue RAL 5010 and Anthracite Grey RAL 7016.

The following options are available at an additional cost:

- Bespoke paint (RAL number required)
- Galvanised version

Type	T	L	B	H	A	Z	F	G
2097.1	5000	3610	2000	360	295	200 x 120	2500 x 2000	580
2097.2	5000	6110	2000	360	295	200 x 120	5000 x 2000	900

- T = Carrying load in kg
- L = Length in mm
- B = Width in mm
- H = Height in mm
- A = Prongs distance in mm
- Z = Prongs dimension in mm
- F = Loading area in mm
- G = Weight in kg

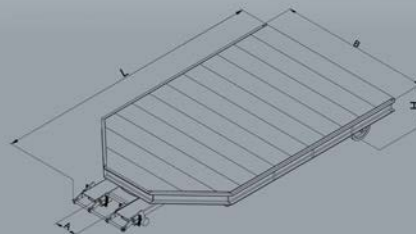

## 2098 Collecting Platform

The 2098 is a large collecting platform with a twist-free base plate and impact-proof edges reinforced with steel tube sections. The forward tipping mechanism is operated from the drivers seat via rope pull.

Available as standard in Pure Orange RAL 2004, Gentian Blue RAL 5010 and Anthracite Grey RAL 7016.

The following options are available at an additional cost:

- 2 fixed and 2 swivel castors
- Bespoke paint (RAL number required)
- Galvanised version

Type	T	L	B	H	A	Z	G
2098.1	2000	2500	1790	390	490	200x80	410
2098.2	2000	3000	1790	390	490	200x80	490
2098.3	2000	4000	1790	390	490	200x80	570

- T = Carrying load in kg
- L = Length in mm
- B = Width in mm
- H = Height in mm
- A = Prongs distance in mm
- Z = Prongs dimension in mm
- G = Weight in kg

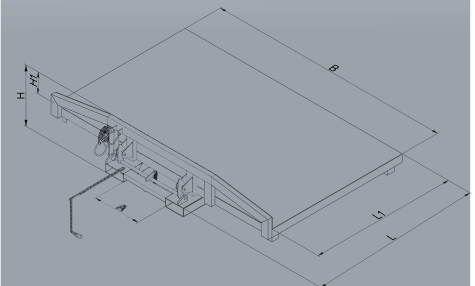



1104 optionally with bearing wheel



### 1104 Brick Barrow paver transport cart

For the transportation of all types of blocks, the 1104 the mechanical operation is via hand lever and the unit has a overloading safeguard. The clamping with is manually adjustable.

Available as galvanised as standard.

The following options are available at an additional cost:

- Replaceable rubber claws
- Support extensions
- Bearing Wheel

Type	T	W	H	H1	B	B1	G
1104.1	400	570 - 1050	1635	900	1190	200	75

- T = Carrying load in kg
- W = Open width in mm
- H = Height in mm
- H1 = Height of the sheet in mm
- B = Width of the sheet in mm
- B1 = Length of the clamping force in mm
- G = Weight in kg

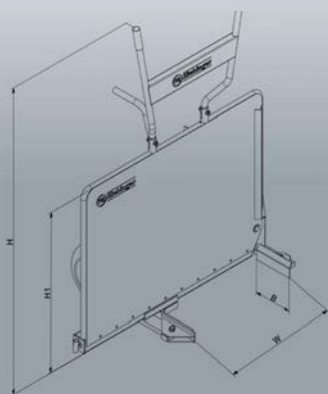

Technical modifications reserved. Figures also show extras.

### 1106 All Terrain Pallet Truck

Designed for the transportation of palletised material, the 1106 is made of solid steel construction with a load capacity of 2000kg. Loads are lifted via a manually controlled hydraulic system and large rubber wheels ensure smooth movement over uneven terrain.

Available as standard in Pure Orange RAL 2004, Gentian Blue RAL 5010 and Anthracite Grey RAL 7016.

The following options are available at an additional cost:

- Bespoke paint (RAL number required)

Type	T	PB	PL	A	Z	HH	G
1106.3	1500	900	1250	220-600	60x45 bis 280	200	

- T = Carrying load in kg
- PB = Width of the pallet in mm
- PL = Length of the pallet in mm
- A = Prong distance in mm
- Z = Weight in kg

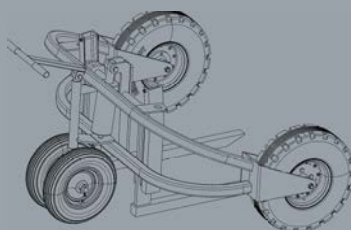

### 1108 Sack Truck

Rugged tubular steel construction with an approximate load capacity of 300kg.

Available as standard in Pure Orange RAL 2004, Gentian Blue RAL 5010 and Anthracite Grey RAL 7016.

As standard, the hand truck is fitted with 260/85 pneumatic tyres.

The following options are available at an additional cost:

- Solid rubber tyre 200/50
- Bespoke paint (RAL number required)
- Galvanised version

Type	T	H	B	L	B1	G
1108	300	1110	510	115	450	12

- T = Carrying load in kg
- H = Height in mm
- B = Width in mm
- L = Length of the sheet in mm
- B1 = Width of the sheet in mm
- G = Weight in kg

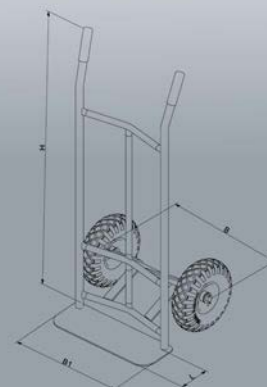



Drum lifter 2211 .....50



Drum lifter 2212 .....50



Drum gripper 2215 .....50



Drum gripper 2216 .....51



Drum lifter for forklift 2218 .....51



Drum gripper 2219 .....51



Drum lifting beam 2221 .....52



Drum clamp 2222 5.....2



Drum tongs 2223 .....52



Drum and dustbin tipper 2231 .....53



Drum tipper 2234 .....53



Drum tipper 2235 .....53



Drum turner 2236 .....54



Mobile drum turner 2241 .....54



Drum trolley 2242 .....55



Drum tipper 2245 .....55



Drum roller 2246 .....55





Robust. Clever. Eichinger.

# HANDLE WITH CARE

More Information in German language with videos



Drum handling on [eichinger-industrie.de](http://eichinger-industrie.de)



## 2211 Drum Grab steel and plastic drums

The 2211 is a forklift attachment for lifting, loading and moving plastic and steel barrels safely and reliably. Designed to managed volumes of 120L - 220L the barrel grab can be adjusted to fit round, square and conical barrels.

With a stabilising rubber barrier to avoid damage to the barrel, the unit is of robust construction.

Lacquering as standard in Pure Orange RAL 2004, Gentian Blue RAL 5010 and Anthracite Grey RAL 7016 and partially zinc dipped.

The following options are available at an additional cost:

- Bespoke paint (RAL number required)
- Galvanised version

Type	NO	T	L	B	H	L1	A	Z	G
2211	1	800	1240	580	700	65-150	160	200x80	128

- NO = Number of barrels
- T = Carrying load in kg
- L = Length in mm
- B = Width in mm
- H = Height in mm
- L1 = Variability of the stabilising buffer in mm
- A = Prong distance in mm
- Z = Prong cross section in mm
- G = Weight in kg

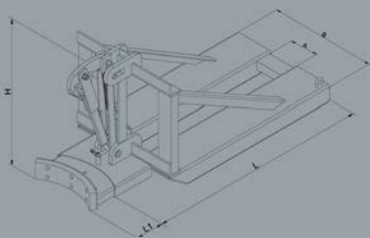

## 2212 Drum Grab multi barrel, steel and plastic drums

The 2212 offers the ability to lift, load and move up to 2 barrels (L-ring, clamping ring cover, beaded barrel, square barrels etc) at a time. Constructed from steel sections and braces, the zinc dipped grab mechanisms provide a high clamping force. The grab mechanisms are screwed to the unit for easy removal for maintenance or replacement of parts.

With a stabilising rubber barrier to avoid damage to the barrel, the unit is of robust construction.

Lacquering as standard in Pure Orange RAL 2004, Gentian Blue RAL 5010 and Anthracite Grey RAL 7016 and partially zinc dipped.

The following options are available at an additional cost:

- Hydraulic clamping protection
- Extended docking pockets
- Bespoke paint (RAL number required)
- Galvanised version

Type	NO	T	L	B	H	L1	A	Z	G
2212	2	800	1240	800	700	65-150	460	200x80	180

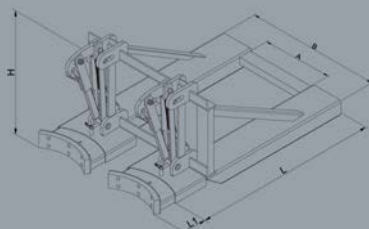

## 2215 Drum Grab

The 2215 is designed for the transportation of metal and plastic L-ring barrels and comes with one, two or three height adjustable grab heads. The barrel is loaded onto the unit from the top edge and automatically releases the barrel once set down onto a solid surface. The holding jaws have a dense rubber coating and protect the barrels from damage.

Lacquering as standard in Pure Orange RAL 2004, Gentian Blue RAL 5010 and Anthracite Grey RAL 7016 and partially zinc dipped.

The following options are available at an additional cost:

- Bespoke paint (RAL number required)
- Galvanised version

Type	NO	T	L	B	H	G
2215.1	1	500	1150	600	1000	105
2215.2	2	1000	1150	1000	1000	163
2215.3	3	1000	1150	1600	1000	212

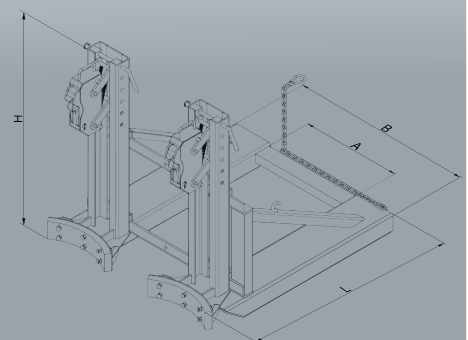

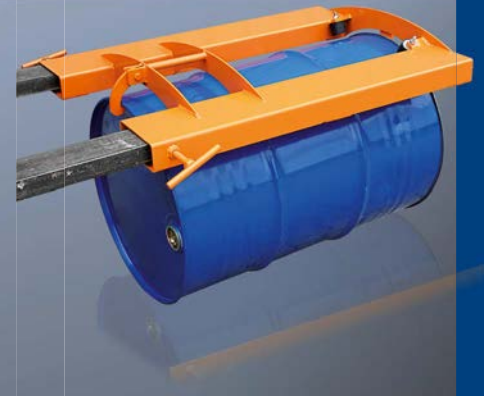

**2216 Drum Lifter**  
200L drums with auto locking

The 2216 is a forklift mounted attachment for lifting and transportation of ring and beaded barrels. When positioned under the bead groove, the grab will open with light pressure to fit the barrel. It will then clamp around the circumference of the barrel to ensure secure lifting/transportation.

Available as standard in Pure Orange RAL 2004, Gentian Blue RAL 5010 and Anthracite Grey RAL 7016.

The following options are available at an additional cost:

- Bespoke paint (RAL number required)
- Galvanised version

Type	NO	T	L	B	H	A	Z	G
2216.1	1	500	1285	710	150	300	200x80	80
2216.2	2	1000	1285	1250	150	300	200x80	115

**2218 Drum Lifter**  
standing drums

The forklift attachment for transporting drums is available in a version for 1 or 2 plastic drums. The jaws of the drum lifter open automatically when the drums are set down. Includes chain to prevent unintentional slipping.

Available as standard in Pure Orange RAL 2004, Gentian Blue RAL 5010 and Anthracite Grey RAL 7016.

The following options are available at an additional cost:

- Bespoke paint (RAL number required)
- Galvanised version

Type	NO	T	L	B	H	A	Z	G
2218.1	1 / 120	300	1330	550	385	170	180x70	50
2218.2	1 / 220	360	1380	650	485	240	180x70	55
2218.3	2 / 120	600	1330	980	385	240	180x70	73
2218.4	2 / 220	720	1380	1170	485	240	180x70	85

**2219 Drum Grab**  
lying drums

Designed to enable lifting of drums that are laying down, the grab is positioned over the lying barrel and locked into place with a grabbing hook. Two rubber plugs on each end secure the barrel without damage. The attachment is fixed to the forklift prongs with wing screws.

Available as standard in Pure Orange RAL 2004, Gentian Blue RAL 5010 and Anthracite Grey RAL 7016.

The following options are available at an additional cost:

- Bespoke paint (RAL number required)
- Galvanised version

Type	T	L	B	H	A	Z	G
2219	300	990	710	125	370	160x60	30

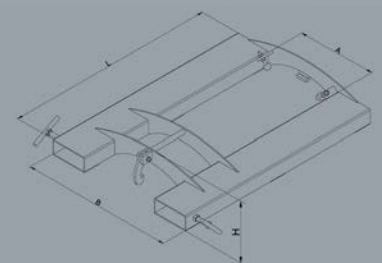
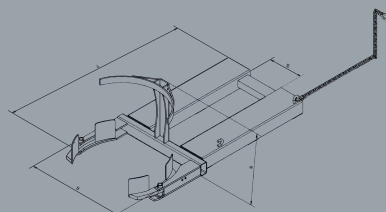
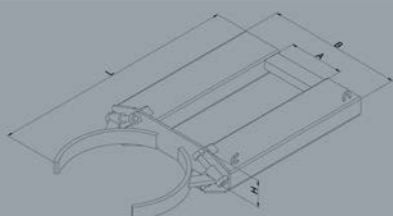

Technical modifications reserved.  
Figures also show extras.

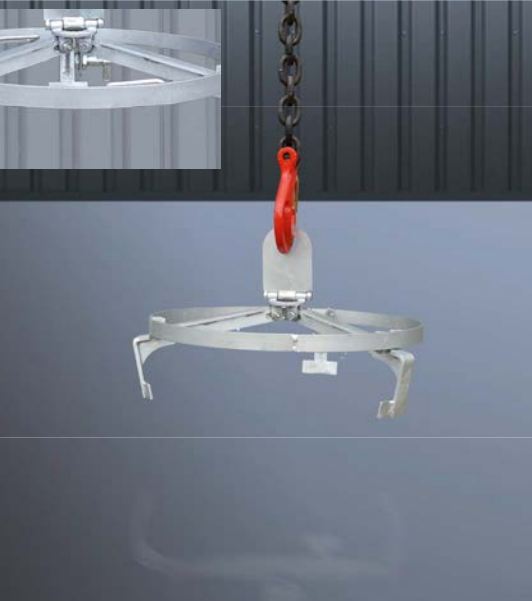

## 2221 Drum Spreader Beam for 200 litre steel drums

The 2221 is a ring spreader beam designed for gripping and lifting 200 litre steel drums from above. Drums can be lifted in and out of vertical containers or placed in difficult to reach places. It comes complete with a 3 point clamping system to enable easy attachment at the barrel ring and is hinged for vertical lifting.

For use with the Eichinger 2081 and 2082 Extending Jib and 2084 and 2985 Fork Load Hook. Comes galvanised as standard.

The following options are available at an additional cost:

- Bespoke paint (RAL number required)

Type	EØ	T	S	H	G
2221	610	300	540-600	150	7

EØ = Barrel size up to in mm  
 T = Carrying load in kg  
 S = Clamping range in mm  
 H = Height in mm  
 G = Weight in kg

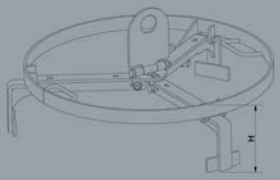

## 2222 Drum Clamp

The drum clamp has been designed to automatically clamp barrels for lifting from the top edge to the barrel ring. The screwed and welded design utilises a barrel stabiliser which fixes under the barrel edge to prevent unintentional slipping whilst in use.

Suitable for barrels up to 220L, the 2222 is for use with the Eichinger 2081 and 2082 Extending Jib and the 2084 and 2985 Fork Load Hook.

Available as standard in Pure Orange RAL 2004, Gentian Blue RAL 5010 and Anthracite Grey RAL 7016.

The following options are available at an additional cost:

- Bespoke paint (RAL number required)
- Galvanised version

Type	T	L	B	H	G
2222	350	540	130	540	9

T = Carrying load in kg  
 L = Length in mm  
 B = Width in mm  
 H = Height in mm  
 G = Weight in kg

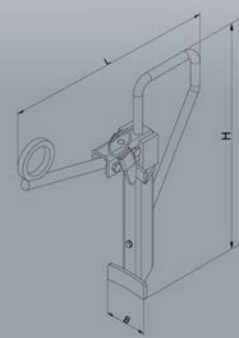

## 2223 Drum Gripper

Adjustable 'scissor' style gripping tool for loading and unloading horizontally stored barrels.

Suitable for barrels up to 220L, the 2223 provides secure grip at the barrel edges and is designed to be used with the Eichinger 2081 and 2082 Extending Jib and the 2084 and 2985 Fork Load Hook.

Comes galvanised as standard. The following options are available at an additional cost:

- Bespoke paint (RAL number required)

Type	Application area	T	G
2223	For metal barrels from 60 l up to 200 l	360	13

T = Carrying load in kg  
 G = Weight in kg





## 2231 Drum Gripper forklift or craneable

Designed for use with a forklift using docking pockets or a crane via chains on the crane hook, the 2231 is suitable for moving, tipping and turning barrels and waste containers of up to 240L.

The barrels are held in place by a prismatic steel sheet and tensioning belt. The tipping procedure operated using the crank handle or chain pulley – dependent on which version is being used.

Available as standard in Pure Orange RAL 2004, Gentian Blue RAL 5010 and Anthracite Grey RAL 7016.

The following options are available at an additional cost:

- Bespoke paint (RAL number required)
- Galvanised version

Type	K	T	L	B	H	D	A	Z	G
2231.1 Hand crank	400	1010	1070	420	360°	640	200x80	120	
2231.2 Chain pulley	400	1145	1125	515	360°	640	200x80	125	

- K = Tipping procedure
- T = Carrying load in kg
- L = Length in mm
- B = Width in mm
- H = Height in mm
- D = Rotation angle
- A = Prong distance in mm
- Z = Prong cross section in mm
- G = Weight in kg

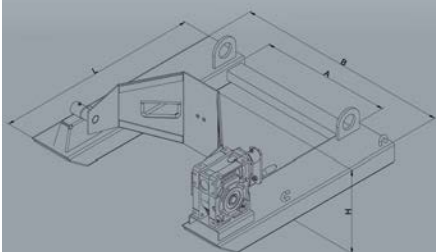

Technical modifications reserved.  
Figures also show extras.

## 2234 Drum Tipper forklift only

Forklift operated attachment for moving, tipping and turning beaded barrels.

The barrels are held in place with steel belts and the tipping mechanism is operated via hand cranks, chain pulley or hydraulic, depending on which version of the unit is being used.

Available as standard in Pure Orange RAL 2004, Gentian Blue RAL 5010 and Anthracite Grey RAL 7016.

The following options are available at an additional cost:

- Bespoke paint (RAL number required)
- Galvanised version

Type	K	T	L	B	H	D	A	Z	G
2234.1 Hand crank	360	1270	1090	550	360°	650	200x80	115	
2234.2 Chain pulley	360	1270	1150	635	360°	650	200x80	118	
2234.3 Hydraulic	360	1270	1090	465	360°	650	200x80	105	

- K = Tipping procedure
- T = Carrying load in kg
- L = Length in mm
- B = Width in mm
- H = Height in mm
- D = Rotation angle
- A = Prong distance in mm
- Z = Prong cross section in mm
- G = Weight in kg

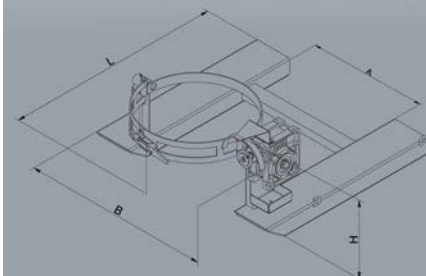

## 2235 Drum Tipper forklift only

The 2235 is designed for moving, tipping and turning beaded barrels secured by clamp at the top and bottom edge of the barrel, with a steel belt which secures the middle. The tipping procedure is operated via hand crank or chain pulley depending on the version.

Available as standard in Pure Orange RAL 2004, Gentian Blue RAL 5010 and Anthracite Grey RAL 7016.

The following options are available at an additional cost:

- Bespoke paint (RAL number required)
- Galvanised version

Type	K	T	L	B	H	D	A	Z	G
2235.1 Hand crank	360	1850	1115	720	360	520	200x80	155	
2235.2 Chain pulley	360	1850	1115	720	360	520	200x80	160	

- K = Tipping procedure
- T = Carrying load in kg
- L = Length in mm
- B = Width in mm
- H = Height in mm
- D = Rotation angle
- A = Prong distance in mm
- Z = Prong cross section in mm
- G = Weight in kg

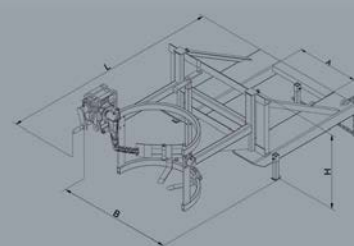

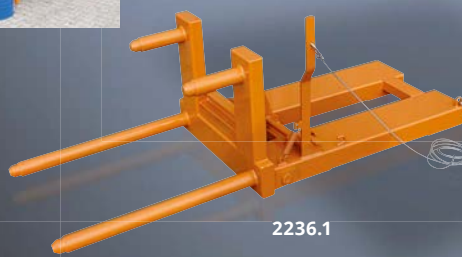

2236.1

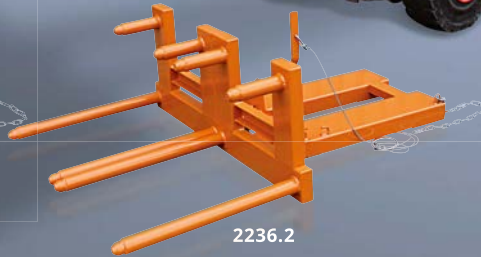

2236.2



2241.1

## 2236 Drum Turner for 1 or 2 drums

The 2236 is the ideal equipment for transportation of up to 2 barrels at a time using the rope pull at the drivers seat. The rope is used for 'tipping' the lying barrel and the barrel turning unit is used for picking up vertically standing barrels – the barrel is then tipped using the forklift.

The unit will automatically lock the barrel in place when it is at an 8 degree angle.

Available as standard in Pure Orange RAL 2004, Gentian Blue RAL 5010 and Anthracite Grey RAL 7016.

The following options are available at an additional cost:

- Bespoke paint (RAL number required)
- Galvanised version

Type	NO	T	L	B	H	A	Z	G
2236.1	1	500	1850	690	670	200	200x80	100
2236.2	2	1000	1850	1295	670	200	200x80	140

- NO = Number of drums  
 T = Carrying load in kg  
 L = Length in mm  
 B = Width in mm  
 H = Height in mm  
 A = Prong distance in mm  
 Z = Prong cross section in mm  
 G = Weight in kg

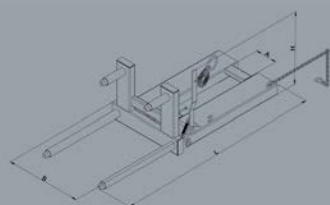

2241.1



## 2241 Drum Rotator

A solidly constructed hand trolley designed specifically for moving, tipping and turning beaded drums. The barrels are held in place with steel, locking belts. The tipping mechanism is operated via a hand crank.

Available as standard in Pure Orange RAL 2004, Gentian Blue RAL 5010 and Anthracite Grey RAL 7016.

The following options are available at an additional cost:

- Bespoke paint (RAL number required)
- Galvanised version

Type	Specifica-tion	T	L	B	H	HH	D	G
2241.1	mechanical	350	1315	1135	1940	1100	270	200

- T = Carrying load in kg  
 L = Length in mm  
 B = Width in mm  
 H = Height in mm  
 HH = Height of stroke in mm  
 D = Tipping angle up to  
 G = Weight in kg

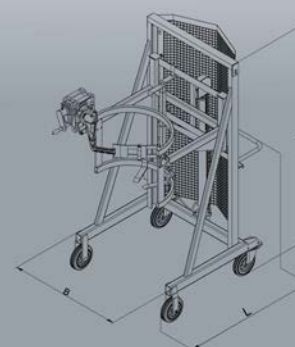



## 2242 Drum Trolley

A hand cart with air-filled tyres, the 2242 has been designed for the manual movement of beaded barrels. Manufactured with rounded holders and supported by 4 polyamide rollers, the support bracket ensure the barrel is secure within the unit. The barrel can be transported either vertically or horizontally.

Available as standard in Pure Orange RAL 2004, Gentian Blue RAL 5010 and Anthracite Grey RAL 7016.

The following options are available at an additional cost:

- Bespoke paint (RAL number required)
- Galvanised version

Type	L	B	H	G
2242	880	655	1650	54

L = Length in mm  
B = Width in mm  
H = Height in mm  
G = Weight in kg

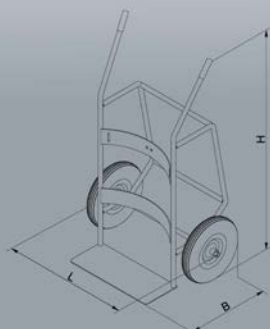

Technical modifications reserved.  
Figures also show extras.

## 2245 Drum Tipping Trolley

A hand cart with air-filled tyres, the 2245 has been designed for the manual movement of beaded barrels. Manufactured with rounded holders and supported by 4 polyamide rollers, the support bracket ensure the barrel is secure within the unit. The barrel can be transported either vertically or horizontally.

Available as standard in Pure Orange RAL 2004, Gentian Blue RAL 5010 and Anthracite Grey RAL 7016.

The following options are available at an additional cost:

- Bespoke paint (RAL number required)
- Galvanised version

Type	L	B	H	G
2245	880	635	1650	53

L = Length in mm  
B = Width in mm  
H = Height in mm  
G = Weight in kg

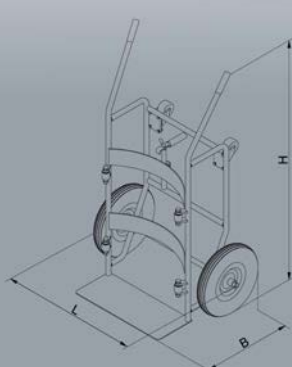

## 2246 Drum Roller

The 2246 is a quick solution for moving vertical barrels. A stable steel ring with 4 heavy duty castors, strengthened with cross welded brackets, the barrel can be lifted onto the unit manually manoeuvred.

Available as standard in Pure Orange RAL 2004, Gentian Blue RAL 5010 and Anthracite Grey RAL 7016.

The following options are available at an additional cost:

- Bespoke paint (RAL number required)
- Galvanised version

Type	NO	T	L	B	H	DØ	G
2246.1	1	500	840	840	150	610	22

NO = Number of drums  
L = Length in mm  
B = Width in mm  
H = Height in mm  
DØ = Diameter in mm  
G = Weight in kg

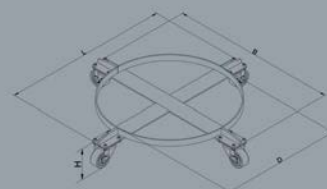



Drum pallet 2261 .....58



Shelf drum pallet 2262 .....58



Drum stacking pallet 2263 .....58



Drum filling station 2271 .....58



Filling station 2272 .....59



Drum rack 2275 .....59



Environmental protection cabinet 3030 .....59

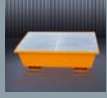

Drain Pan 3010 .....60



IBC drip tray 3010 .....60



Drain Pan 3012 .....61



Drain Pan 3013 .....61





Robust. Clever. Eichinger.

# STORE BARRELS & DRUMS

More Information in German language with videos

Environmental storage technology on [eichinger-industrie.de](http://eichinger-industrie.de)





## 2261 Drum Pallet modular, stacking

A quick and easy, standalone, barrel stacking solution, each pallet can store 2 barrels. The units can be aligned horizontally and stacked vertically. Barrels can also be moved once on the pallet using the forklift docking pockets. Manufactured from zinc-dipped steel, the pallets are twist free and have reinforced support edges. (Can be used with the Drum Filling Station 2271) As standard as galvanised.

Optionally at an additional cost:  
 • Bespoke paint (RAL number required)

Type	L	B	H	A	Z	G
2261	680	1200	400	440	200 x 80	35

L = Length in mm  
 B = Width in mm  
 H = Height in mm  
 A = Prong distance in mm  
 Z = Prong cross section in mm  
 G = Weight in kg

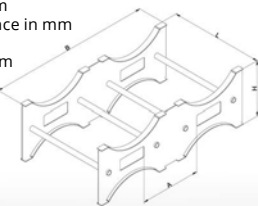

## 2262 Drum Pallet for use with racking

The rack barrel pallet is designed to securely store barrels and drums on racking. Manufactured from steel in an inverted V, the barrel sits horizontally along the indent which stabilises the barrel against rolling and slipping.

Available as standard in Pure Orange RAL 2004, Gentian Blue RAL 5010 and Anthracite Grey RAL 7016 and galvanised.

Type	L	B	H	Z	G
2262	1120	580	130	140 x 40	30

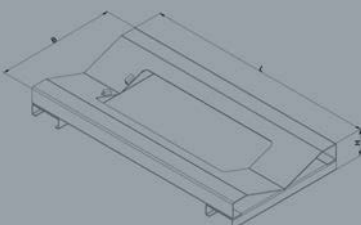

## 2263 Drum Stacking Pallet with integrated drain pan

The 2263 is designed for the vertical storage of barrels and drums. Complete with a built in oil and watertight drain pan, the barrels stand on robust steel grates, that are removable for cleaning and maintenance. Each unit can store 2 barrels and the unit can be moved around site using a forklift via the docking pockets or crane via a chain.

Available as standard in Pure Orange RAL 2004, Gentian Blue RAL 5010 and Anthracite Grey RAL 7016.

The following options are available at an additional cost:

- Bespoke paint (RAL number required)
- Galvanised version

Type	NO	L	B	H	A	Z	G
2263	2	1515	1120	1465	685	200 x 80	150

NO = Number of barrels (200l)  
 L = Length in mm  
 B = Width in mm  
 H = Height in mm  
 A = Prong distance in mm  
 Z = Prong cross section in mm  
 G = Weight in kg

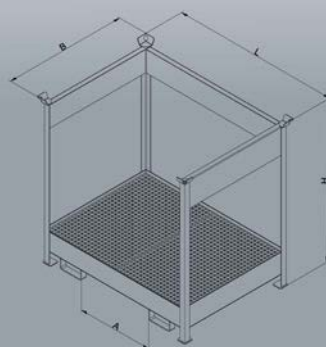

## 2271 Drum Filling Station

A practical addition to the 2261 Drum Pallet, the 2271 is placed on the filling station to allow easy access to the barrels for re-filling. The unit comes complete with an oil and water tight drain pan and removable pot to catch any spillages.

Available as standard in Pure Orange RAL 2004, Gentian Blue RAL 5010 and Anthracite Grey RAL 7016.

The following options are available at an additional cost:

- Bespoke paint (RAL number required)
- Galvanised version
- Stainless Steel
- Removable Pot can be zinc-dipped
- Drum support 2261

Type	NO	L	B	H	G
2271.1	2	1300	1460	735	105
2271.2	4	1300	2960	735	175

NO = Number of barrels (200l)  
 L = Length in mm  
 B = Width in mm  
 H = Height in mm  
 G = Weight in kg

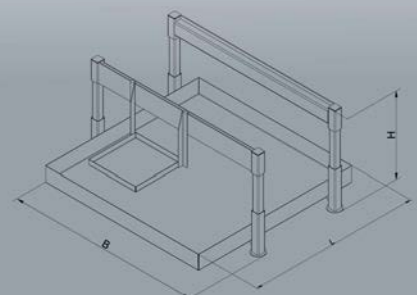

3012.40 Drum rack as standard with rigid drum support



Equipment example:

2272.9 with 2x 2272.11

2272.9 with 2272.12 + 2272.11

2272.9 with 2272.11 + 2272.12

2272.7 + 2272.8

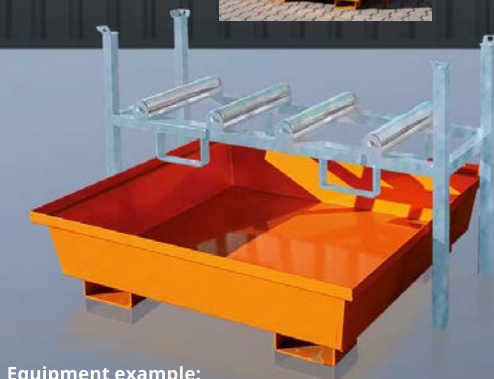

Equipment example: 2275.3 with 2x 2275.6 + 2275.4



## 2272 Drum Filling Station

Constructed from high grade steel, the barrels and drums can be placed on the rack shelving with roller and barrel supports. The base unit comes complete with an oil and watertight drain pan and removable, zinc-dipped grating.

Available as standard in Pure Orange RAL 2004, Gentian Blue RAL 5010 and Anthracite Grey RAL 7016.

The following options are available at an additional cost:

- Bespoke paint (RAL number required)
- Galvanised version

Type		V	L	B	H	G
2272.1	Drain pan	60	510	830	220	38
2272.2	Grating		400	800	30	6
2272.3	Stacking rack, without support	540	540	530	13	
2272.4	Drain pan	60	910	830	160	47
2272.5	Grating		800	800	30	12
2272.6	Stacking rack, without support	940	540	530	15	
2272.7	Drain pan	60	1310	830	130	56
2272.8	Grating		1200	800	30	19
2272.9	Stacking rack, without support	1340	540	530	19	
2272.10	Barrel support		515	360	75	8
2272.11	Carboy stand			300		
2272.12	Swivel roller support		530	360	110	10

V = Draining volume in l  
L = Length in mm  
B = Width in mm  
H = Height in mm  
G = Weight in kg

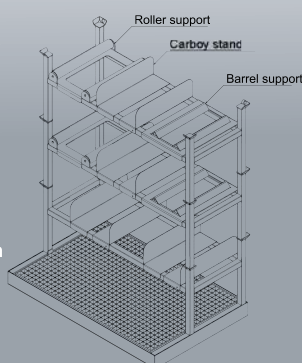

Configure your drum filling station with modules from the list.

Technical modifications reserved. Figures also show extras.

## 2275 Drum Rack

Manufactured from high grade steel sections, the 2275 comes with roller supports for positioning the barrels. A separate drain pan protects the standing surface from spillages and leakages.

Available as standard in Pure Orange RAL 2004, Gentian Blue RAL 5010 and Anthracite Gre RAL 7016.

The following options are available at an additional cost:

- Galvanised drain pan gratings
- Transportation protection
- Bespoke Paint (RAL number required)
- Galvanised version
- Can holder

Type		NO	L	B	H	A	Z	G
2275.1	Drum rack*	1x200l	1120	540	880	480	200 x 100	20
2275.2	Drain pan		1220	820	420	520	200 x 95	80
2275.3	Drum rack*	2x200l	1420	540	880	480	200 x 100	25
2275.4	Drain pan		1230	1230	340	560	200 x 95	115
2275.5	Carboy stand							
2275.6	Roller supports		530	360	110			10

\* Drum rack with support

NO = Number of barrels (200l)  
L = Length in mm  
B = Width in mm  
H = Height in mm  
G = Weight in kg



2275.1 with can holder and roller supports



2275.3 with can holder and roller supports

Configure your drum filling station with modules from the list.

2 x 2275.3 + 2275.4

## 3030 Environment Protection Cabinet

Sheet steel protection cabinet for the appropriate storage of water endangering material. The unit comes with a built in drain pan to protect against unintentional leaks and spillages. The 3030 come with integrated forklift pockets for easy movement around site.

Available as standard in Pure Orange RAL 2004, Gentian Blue RAL 5010 and Anthracite Grey RAL 7016.

Type	V	L	B	H	A	Z	G
3030.2	200	1630	800	1575	/	200 x 80	300
3030.7	400	1570	1660	1705	690	200 x 80	510
3030.12	1000	1780	1580	2340	580	200 x 80	800

The following options are available at an additional cost:

- Company Logo on the door
- Binding agent starter set
- Bespoke Paint (RAL number required)
- Galvanised version



V = Draining volume in l  
L = Length in mm  
B = Width in mm  
H = Height in mm  
A = Prong distance in mm  
Z = Prong cross section in mm  
G = Weight in kg

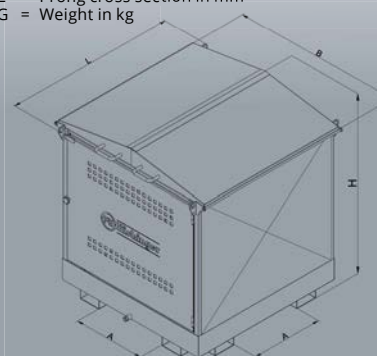



3010.1-4  
standard version  
with grating



3010.5-8  
delivery without grating

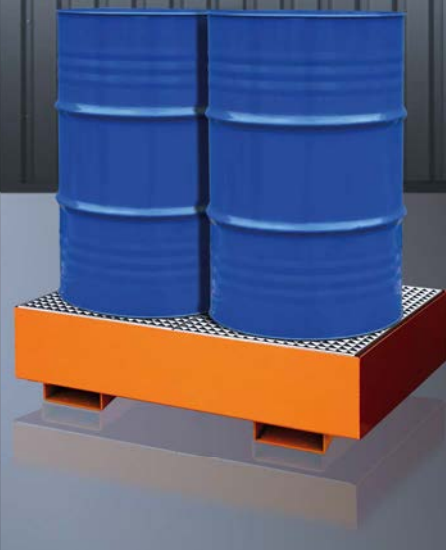

## 3010 Drain Pan with tapered side walls

An extra deep, oil and watertight drain pan with tapered walls and galvanised grating. Built to relevant safety standards, the base of the 3010 comes with docking pockets for use with a forklift. Available in various sizes and depths.

Can be supplied with or without grating.

Available as standard in Pure Orange RAL 2004, Gentian Blue RAL 5010 and Anthracite Grey RAL 7016.

The following options are available at an additional cost:

- Bespoke paint (RAL number required)
- Galvanised version
- special sizes

Type	NO	V	L	B	H	A	Z	G
<b>Version with grating</b>								
3010.1	1	210	820	820	575	130	200x95	55
3010.2	2	220	1220	820	440	520	200x95	90
3010.3	4	240	1230	1230	360	560	200x95	115
3010.4	4	240	2400	820	315	450	200x95	160
<b>Version without grating</b>								
3010.5	-	210	820	820	575	130	200x95	45
3010.6	-	220	1220	820	440	520	200x95	80
3010.7	-	240	1230	1230	360	560	200x95	105
3010.8	-	240	2400	820	315	450	200x95	150

NO= Number of barrels (200 l)  
V = Draining volume in l  
L = Length in mm  
B = Width in mm  
H = Height in mm  
U = Underride height in mm  
G = tare weight in kg

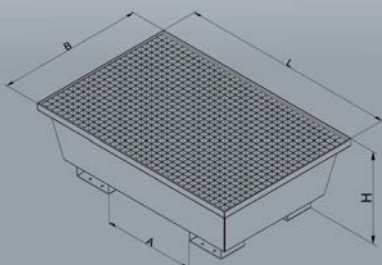

Configure your drum filling station  
with modules from the list.

## 3010 IBC Drip Tray with tapered side walls

Extra deep, oil and watertight drain pan with tapered walls and galvanised grating.

Specifically designed for secure storage of IBC containers. The unit is built to relevant safety standards and comes with docking pockets for use with a forklift.

Available as standard in Pure Orange RAL 2004, Gentian Blue RAL 5010 and Anthracite Grey RAL 7016.

The following options are available at an additional cost:

- Bespoke paint (RAL number required)
- Galvanised version
- special sizes

Type	V	L	B	H	A	Z	G
<b>Version with grating</b>							
3010.20	1000	1450	1450	780	755	200x95	195
3010.21	1000	2600	1450	515	850	200x95	290

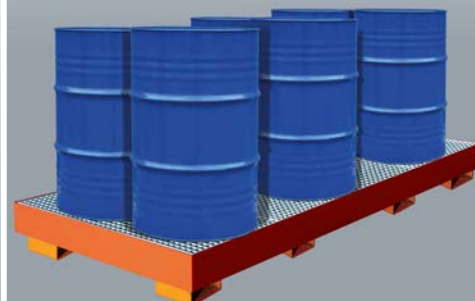
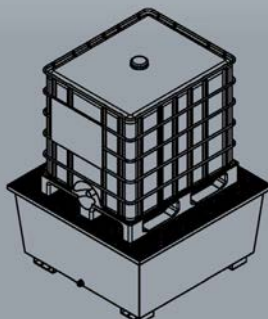
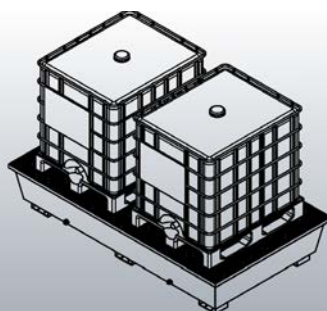

3012.40 Drum rack as standard with rigid drum support

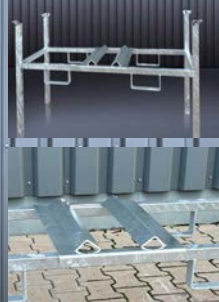

3012.3-4 (see price list) Delivery without grating



### 3012 Drain Pan straight walled

Straight walled, oil and watertight drain pan with galvanised, removable grating. The 3012 comes with legs with integrated docking pockets for use with a forklift.

Available as standard in Pure Orange RAL 2004, Gentian Blue RAL 5010 and Anthracite Grey RAL 7016.

The following options are available at an additional cost:

- 2 fixed and 2 swivel castors
- Bespoke paint (RAL number required)
- Galvanised version
- Various sizes

Type	NO	V	L	B	H	U	G
<b>Version with grating</b>							
3012.1	2	235	1280	815	375	100	95
3012.2	4	340	1280	1280	355	100	125
3012.5	1	220	815	815	480	100	78
3012.6	4	230	1750	1280	245	100	155
3012.7	6	310	2080	1280	260	100	175
3012.8	4	265	2400	815	275	100	148
3012.9	8	360	2650	1280	245	100	220
3012.10	10	230	3250	1280	255	100	285
3012.11	3	220	2080	815	275	100	125
<b>Version without grating</b>							
3012.3	2	235	1280	815	375	100	75
3012.4	4	340	1280	1280	355	100	95

NO= Number of barrels (200 l)  
 V = Draining volume in l  
 L = Length in mm  
 B = Width in mm  
 H = Height in mm  
 U = Underride height in mm  
 G = tare weight in kg

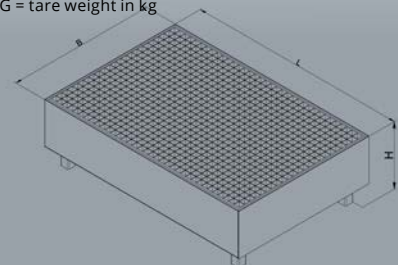

Configure your drum filling station with modules from the list.

### 3012.40 Drum Rack galvanised



optionally with swivelling roller supports and can holder

Type	NO	L	B	H	G
3012.40 Galvanised drum rack	1x 200l	1420	540	880	20
3012.41 Galvanised drum rack	2x 200l	1420	540	880	25
3012.42 Galvanised drum rack	3x 60l	1420	540	880	30

3012.40 with can holder and roller supports



3012.41 with can holder and roller supports

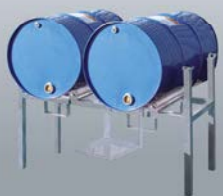

3012.42 with can holder and roller supports

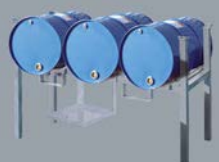

### 3013 Drain Pan

Extra deep, oil and watertight drain pan with straight side walls – available with or without removable grating. This design comes complete with handle and 2 fixed and 2 swivel castors for manual manoeuvring.

Available as standard in Pure Orange RAL 2004, Gentian Blue RAL 5010 and Anthracite Grey RAL 7016.

The following options are available at an additional cost:

- Bespoke paint (RAL number required)
- Galvanised version
- Various sizes

Type	V	L	B	H	G
<b>Version without grating, without handle</b>					
3013.1	220	815	815	680	58
<b>Version with grating, with handle</b>					
3013.2	220	815	815	680	88
<b>Version with grating, with handle</b>					
3013.3	220	850	815	1240	106

V = Draining volume in l  
 L = Length in mm  
 B = Width in mm  
 H = Height in mm  
 G = Weight in kg

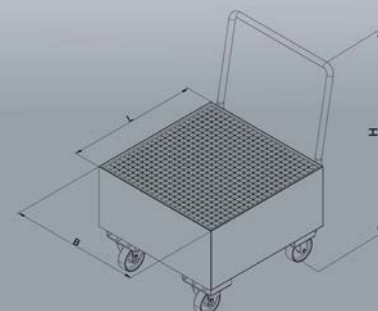

Technical modifications reserved. Figures also show extras.



## From Bavaria to the world

Authorised specialist dealers are your contacts for our products worldwide. The multilingual, qualified employees at the Muehlhausen site provide service support, advice and assistance to customers and trading partners.

Eichinger Industrie:  
wherever lifting and loading takes place.



Would you like to become a trading partner of Eichinger Industrie?  
Would you like our expertise for a special solution?  
Can we supply you directly?

We look forward to hearing from you on +49 8462 34 89 99-0

## General Terms of Sale, Delivery and Payment

### I. General

- All deliveries, services and quotations, including all incidental services, shall be governed exclusively by these terms of business. These shall apply to any future business relations as well, even if this is not explicitly agreed. These terms shall be deemed to have been accepted no later than the receipt of the goods delivered or service rendered. Any counterconfirmation by the Customer with reference to its terms of business or terms of purchase is hereby refuted.
- Any agreements, subsidiary agreements, amendments, additions and assurances made prior to and upon acceptance of the order shall be effective only if recorded in writing.
- Any drawings, illustrations, dimensions, weights or other specifications shall be binding only if this is explicitly agreed in writing. We reserve the right to make minor alterations in design and execution.

### II. Prices and terms of payment

- The prices in our price lists are without engagement and are quoted ex works plus freight. Value-added tax at the prevailing rate shall be invoiced separately, unless the price lists explicitly quote gross prices.
- For cash deductions, please refer to the individual invoices.
- Employees of the firm are not entitled to accept payments. Payments exempting the Customer from its liabilities can be remitted only to the managing director of the firm or transferred to an account specified by the firm.
- In the event of default, we are entitled to charge interest at a rate which is 4% higher than the prevailing discount rate of the Deutsche Bundesbank, without having to provide any further evidence. We reserve the right to enforce claims for damages going beyond this.
- Cheques and bills shall be accepted by way of payment only. Credits for bills and cheques shall be subject to their receipt, minus expenses, their value date being that date upon which we are able to dispose of the sum in question.

### III. Delivery and performance times

- Any delivery or performance deadlines or periods, whether binding or without engagement, must be specified in writing.
- Delivery and performance periods shall commence on the date of our order confirmation, but not before all the details of the order have been completely clarified.
- If a binding delivery or performance deadline has been exceeded by four weeks, the Customer can submit to the Contractor a written demand for delivery or performance within an appropriate grace period.
- The Contractor shall not be answerable for delays in delivery and performance owing to acts of God and events which severely impair or preclude the Contractor's ability to deliver or perform - in particular strikes, lockouts, official directives etc., including any such events which occur at the Contractor's suppliers or their subcontractors -, even if the deadline or period agreed was binding. Such events shall entitle the Contractor to postpone delivery or performance for the duration of the obstacle plus an appropriate run-in time or to rescind that part of the contract which has not been performed either in part or in its entirety.
- If the obstacle lasts for longer than three months, the Customer, after imposing an appropriate grace period, shall be entitled to rescind that part of the contract which has not been performed. If the delivery period is extended or the Contractor is released from its obligation to perform, the Buyer cannot derive any claims for damages from this. The Contractor can plead such circumstances only if it notifies the Customer of this without delay.
- If the Contractor is in default, the Customer can rescind contract, but only if it has first imposed a grace period of six weeks, commencing upon the receipt by the Contractor of the notice to that end.
- To the extent the Contractor is answerable for its non-adherence to binding periods and deadlines or is in default, the Customer is entitled to compensation in the amount of ½% for every full week of the delay but for no more than a total of 5% of the invoice value of the deliveries and services on which the Contractor has defaulted. There shall be no claims going beyond this, unless the default is attributable at least to gross negligence on the part of the Contractor.
- The Contractor is entitled to effect partial deliveries or render services in part at any time.

### IV. Transfer of risks

All risks shall transfer to the Customer as soon as the shipment has been handed over to the forwarder or has left the Contractor's warehouse in preparation for despatch. If despatch proves impossible for reasons for which the Contractor is not responsible, all risks shall transfer to the Customer as soon as the Customer has been notified that the shipment is ready for dispatch.

### V. Right of rescission

- In the event of a deterioration in the Customer's financial circumstances subsequent to the signing of contract, such as an application for the initiation of bankruptcy proceedings or court composition proceedings or the request for and implementation of an out-of-court settlement, fruitless execution or the protesting of cheques or bills or other events of this nature affecting the Customer, we are entitled to rescind all those parts of the contract which have not yet been performed.
- In the aforementioned cases, we are entitled to take back any goods which, under the reservation of title agreed in VI, are still our property, pending the settlement in full of all outstanding claims.

### VI. Reservation of title

- The Vendor/Contractor reserves its title to the objects delivered (reserved goods) pending the settlement of all claims (including all claims ensuing from the current-account balance) accruing to the Vendor/Contractor on the Buyer/Customer now or in the future, irrespective of the legal basis for the said claims.
- The goods can be processed or modified for the Vendor/Contractor as the manufacturer of the goods, but without obligation for it. If the Vendor's (co-)ownership of the goods is extinguished by their combination, it is hereby agreed that the Vendor/Contractor's (co-)ownership of the combined product shall be made over to the Vendor/Contractor as a proportion of the invoice value of the said product. The Buyer/Customer shall preserve the Vendor/Contractor's (joint) property at no cost to the latter.
- The Buyer/Customer is entitled to process and sell the reserved goods in the course of its ordinary business activities as long as it is not in default. The mortgaging of the goods or transfer of title as collateral are inadmissible. The Buyer/Customer hereby assigns in full to the Vendor/Contractor all claims (including all claims ensuing from a current-account balance) accrued from the resale of the reserved goods or on any other legal basis (insurance, unlawful acts). The Buyer/Customer is empowered, subject to revocation, to collect in its own name the claims assigned to the Vendor/Contractor for its account. These powers of collection can be revoked only if the Buyer/Customer fails to honour its payment obligations.
- The Buyer/Customer is entitled to assign the claims - including the sale of the said claims to factoring banks - only with the written consent of the Vendor/Contractor. In the event of default and if so requested with just cause, the Buyer/Customer shall provide the Vendor/Contractor with the names of the third parties or assignees in question as well as providing the information required for collection and the necessary documents.
- If the reserved goods are seized by third parties, the Buyer/Customer shall plead the Vendor/Contractor's title to the same and notify the Vendor/Contractor forthwith.
- In the event of a breach of contract by the Buyer/Customer - especially default on payment - the Vendor/Contractor is entitled to take back the reserved goods or, if necessary, to demand their assignment by or enforce the claims for restoration of the Buyer/Customer on third parties. The taking back or pledging of the reserved goods by the Vendor/Contractor shall not - to the extent that the hire purchase act is not brought to bear - constitute a rescission of contract.
- To the extent that the value of the collateral provided consistently exceeds the claims secured by more than 10%, the Vendor/Contractor shall release the collateral of its choice if so requested by the Buyer/Customer.

### VI. Warranty

- Any obvious faults shall be reported in writing without delay but no later than within one week of the receipt of the goods.
- The warranty shall be confined to correction work. The Vendor/Contractor can elect to effect a replacement delivery instead of performing the said correction work.
- If neither correction work nor a replacement delivery is possible or if these fail or are refused, the right to a reduction of the purchase price or a rescission of contract can be enforced.
- There shall be no claims going beyond these. The right to damages for the absence of promised features, however, shall remain unaffected.

### VII. Limitation of liability

There shall be no claims to damages for impossibility of performance culpa in contrahendo, the violation of subsidiary contractual obligations and unlawful acts either on the Vendor/Contractor or on its vicarious agents, unless these are attributable to intent or gross negligence. Claims of this nature shall lapse after ½ year.

### VIII. Works contracts

- Works contracts for non-representative goods (customized goods)
- If the contract is terminated for reasons for which the Contractor is answerable the Contractor shall be entitled to remuneration only for the performance rendered prior to the date of termination.
- In all other cases, the Contractor reserves its claim to the agreed remuneration, but subject to the deduction of the expenses saved. Unless the Customer provides evidence to the contrary, the Contractor is entitled to claim 20% of the agreed remuneration or the compensation of the losses actually incurred without having to provide evidence of the same.

### IX. Counterclaims, right of retention

- Counterclaims cannot be set off unless the counterclaim in question is undisputed or legally enforceable.
- There shall be no right of retention based on other contractual relations.

### X. Applicable law, jurisdiction and final provisions

- These terms of business and all the legal relations between the Vendor/Contractor and Buyer/Customer shall be governed by the laws of the Federal Republic of Germany. The terms of the Hague Convention on the International Sale of Goods shall not apply.
- To the extent that the Buyer/Customer is a merchant, judicial person under public law or a bearer of public funds, any disputes ensuing directly or indirectly from this contract shall be settled in Neumarkt i.d.OPf. only.
- If any of the above terms or parts thereof are or become null and void or cease to be an integral part of this contract, the remaining terms shall not be affected. The invalid terms shall be replaced by such terms as best approximate the intended purpose in a legally acceptable manner.



**Eichinger-Industrie GmbH**

Maria-Hilf-Str. 15-21  
92334 Berching

**Visiting & logistics**  
An der Laende 10  
92360 Muehlhausen  
Germany

Telefon: +49 8462 34 89 99-0  
Telefax: +49 8462 34 89 99-9  
sales@eichinger-industrie.de

[www.eichinger-industrie.de](http://www.eichinger-industrie.de)

Your partner for advice and sales:

